

Champ FMVA LED floodlights

Cl. I, Div. 2, Groups A, B, C, D
Cl. I, Zone 2
Cl. II, Groups E, F, G

UL Listed
IECEX/ATEX
Type 4X; IP66

6L

The Champ FMVA LED family

Champ® FMVA LED floodlights are designed to provide full-spectrum, crisp, white light. Seven versions of the FMVA LED are available, from 3,000 to 15,000 lumens, providing ideal solutions for a wide range of harsh and hazardous applications.

Model	Nominal lumens ^A	Watts	Lumens per watt	Equivalent HID luminaire	Energy savings
FMVA3L	3,312	26	129	70W	Up to 75% reduction in energy costs and 150,000 hours of continuous operation
FMVA5L	5,381	40	133	100W	
FMVA7L	7,274	55	132	175W	
FMVA9L	9,479	67	142	250W	
FMVA11L	11,776	82	144	320W	
FMVA13L	13,362	93	143	400W	
FMVA15L	15,183	108	140	500W	

Applications:

- Oil and gas refineries, drilling rigs, petrochemical facilities, food and beverage facilities, platforms, loading docks, tunnels, outdoor wall and stanchion mounted general area lighting, and where flammable vapors, gases, ignitable dusts, fibers or flyings are present
- Locations requiring continuous and consistent light levels in extreme ambient temperatures
- Where extremely corrosive, wet, dusty, hot and/or cold conditions exist
- IP66, Type 4X, marine, wet locations and hose down environments
- Classified and hazardous locations

Features:

- Instant illumination and restrike
- Better visibility with crisp, white light
- Cold temperature operation/no warm-up required
- Minimum T3C temperature rating – safely operate in the most hazardous environments and any non-hazardous location
- Serviceable drivers
- Easy installation – yoke design to mount to SFA6
- Energy-efficient technology – up to 72% energy savings over HID fixtures
- 60,000 hours of rated life at 55°C – eliminates need for frequent lamp replacement
- Contains no mercury or other hazardous substances
- Shock- and vibration-resistant solid state luminaires have no filaments or glass components that could break – greatly reduces the risk of premature failure
- Operating ambient: -40°C to 65°C (NEC only; IEC: -40°C to 55°C)
- 5 year fixture warranty

Certifications and compliances:

- DesignLights Consortium® Qualified (pending)^E

NEC/CEC:

- Class I, Division 2, Groups A, B, C, D; Class I, Zone 2; Class II, Groups E, F, G
- Wet locations, Type 4X, IP66

UL standards:

- UL844; UL1598; UL1598A; UL8750

IEC standards^H:

- IEC 60079-0, 6th Edition (2011-06) + Corr. 1 (2012-01) + Corr. 2 (2013-12) + I-SH 01 (2013-11) + I-SH 02 (2014-10)/EN 60079-0:2012 + A11:2013
- IEC 60079-7, Edition 5.1 (2017-08)/EN 60079-7: 2015 +A1:2018
- IEC 60079-31, 2nd Edition (2013-11)/EN 60079-31:2014
- IEC 60598-1:2008/EN60598-1:2008
- IEC 60598-2:2008/EN60598-2:2008

IECEX/ATEX^H:

- CE 0359
- IECEX UL15.0029X
- DEMKO 15 ATEX 1377X
- DEMKO 15 ATEX 1383
- Ex II 3 G Ex ec mb IIC T5 Gc Tamb -40° - +40°C
- Ex II 3 G Ex ec mb IIC T5 Gc Tamb -40° - +40°C^G
- Ex ec IIC T5 Gc Tamb -40°C - +40°C
- Ex ec IIC T4 Gc Tamb -40°C - +55°C
- Ex II 2 D Ex tb IIIC T65 Db Tamb -40°C - +40°C
- Ex II 2 D Ex tb IIIC T80 Db Tamb -40°C - +55°C
- Ex tb IIIC T65 Db Tamb -40°C - +40°C
- Ex tb IIIC T80 Db Tamb -40°C - +55°C



Standard materials:

- Lamp housing and adapter – die cast aluminum with Corro-free epoxy powder coat
- Lens – heat- and impact-resistant glass (standard)
- Gaskets – silicone and neoprene
- External hardware – stainless steel

Fixture life:

- Rated life of 60,000 hours at 55°C operating ambient and 24/7 continuous operation for 365 days
- Economic life of 150,000 hours at 25°C ambient

LED system:

- Cool white (5000K, 70 CRI) and warm white (3000K, 80 CRI)
- Custom designed optics – 7x6 standard; 3x3 (optional)

Photometrics:

- Complete photometrics can be found at www.crouse-hinds.com/photometrics

Electrical ratings:

Model	Input power (watts)	Input amps at 120-277 VAC
FMVA3L	25	0.27 - 0.10
FMVA5L	40	0.41 - 0.16
FMVA7L	54-56	0.56 - 0.21
FMVA9L	67-69	0.78 - 0.28
FMVA11L	81-84	0.84 - 0.30
FMVA13L	91-95	0.95 - 0.34
FMVA15L	107-113	1.12 - 0.40

FMVA3L-FMVA15L

Voltage range, VAC ^C	100-277V at 50/60 Hz
Voltage range, VDC	127-250V
Power factor	>0.90 ^D

^ATolerance +/- 10%; at 120 VAC, 25°C ambient, 7x6 optics.

^BRefer to www.designlights.org Qualified Products List under family models for full listing details. Not all models are approved for all application categories.

^CIEC voltage; 100-250 VAC at 50/60 Hz, UNV34 option for FMVA9L-15L only.

^DFor FMVA3L: PF >0.90 from 100-255 VAC. From 255-277V, it varies +/- 10%. All other lumen levels are above 0.90 PF across full voltage range.

^GT4 from -40°C to +40°C when used with 3x3 optic.

^HNot applicable for FMVA9L-15L UNV34.

Champ FMVA LED floodlights

Cl. I, Div. 2, Groups A, B, C, D
Cl. I, Zone 2
Cl. II, Groups E, F, G

UL Listed
IECEX/ATEX
Type 4X; IP66

6L

Versatile design

- Can be used for outdoor or indoor applications, and for a wide range of mounting heights depending on model and light level requirement

Smaller and lighter

- 25% smaller footprint than previous model
- 10 lbs. (4.5 kg) less weight than previous model

Full-frame yoke

- Designed to utilize the SFA6 slipfitter and SWB6 wall mount bracket, making it ideal for retrofit or new installations



High lumen output

- Up to 144 lumens per watt
- Up to 72% energy savings over traditional HID fixtures (compared to 400W MH)



Multiple lens options

- Tempered clear glass lens standard
- Polycarbonate and diffused glass lens options available

Rugged heat sink

- Heat sink designed to perform and provide maximum light levels in high ambient temperatures up to +65°C and as low as -40°C
- Thick walled castings make for a tough, rugged housing that keeps the internal driver and LED temperature down

6L

Champ FMVA LED floodlights

Cl. I, Div. 2, Groups A, B, C, D
Cl. I, Zone 2
Cl. II, Groups E, F, G

UL Listed
IECEX/ATEX
Type 4X; IP66

6L

Ordering information:

Part number example

FMVA7LCY-UNV1-76-M20-S891-BZ

FMVA 7L C Y - UNV1 - 76 - M20 - S891 - BZ

Light source / intensity	
3L	3,312 nominal lumens ^E
5L	5,381 nominal lumens ^E
7L	7,274 nominal lumens ^E
9L	9,479 nominal lumens ^E
11L	11,776 nominal lumens ^E
13L	13,362 nominal lumens ^E
15L	15,183 nominal lumens ^E

Color temperature	
C	5000K, 70 CRI (cool white)
W	3000K, 80 CRI (warm white)

Mounting	
Y	Yoke

Voltage	
/UNV1 ^F	100-277 VAC, 50/60 Hz; 127-250 VDC
/UNV34 ^J	347-480 VAC, 50/60 Hz

Optical distribution	
76	7x6 floodlight pattern optics
33	3x3 floodlight pattern optics

Entries	
BLANK	3/4" NPT
M20	20mm
M25	25mm

Paint	
BLANK	Gray
BZ	Bronze
WH	White

Lens material	
BLANK	Clear glass lens
S891	Diffused glass lens
S903	Polycarbonate lens

Options:

Description	Suffix
• Diffused glass lens	S891
• Polycarbonate lens	S903

Accessories (ordered separately):

Description	Cat. #
• Bull horn, gray	BLHN
• Bull horn, bronze	BLHN-BZ
• Bull horn, white	BLHN-WH
• Bolt-on visor	DSV2
• Bolt-on wire guard	P62
• 316 stainless steel safety cable	SC831
<i>Can be added in the field</i>	
• Floodlight slipfitter	SFA6
• Slipfitter wall mount adapter	SWB6

Replacement driver kits (ordered separately)

FMVA 3-5-7L UNV1 DRIVER KIT	UNV1 Replacement driver kit for 3L, 5L and 7L models
FMVA 9-11-13L UNV1 DRIVER KIT	UNV1 Replacement driver kit for 9L, 11L and 13L models
FMVA 15L UNV1 DRIVER KIT	UNV1 Replacement driver kit for 15L model
FMVA 9L-11L UNV34 DRIVER KIT	UNV34 Replacement driver kit for 9L and 11L models
FMVA 13L-15L UNV34 DRIVER KIT	UNV34 Replacement driver kit for 13L and 15L models

^E 7x6 model.

^F IEC voltage; 100-250V at 50/60 Hz.

^J Available for FMVA9L-15L only.

Champ FMVA LED floodlights

Cl. I, Div. 2, Groups A, B, C, D
Cl. I, Zone 2
Cl. II, Groups E, F, G

UL Listed
IECEX/ATEX
Type 4X; IP66

6L

Temperature performance data:

Model	Ambient temp. °C	Class I, Div. 2	Class II, Div. 1	Simultaneous rating				Minimum wire temp. °C
				Class I, Div. 2; Div. 1	Class I, Zone 2	ATEX 3G	ATEX 2D	
FMVA3L-FMVA15L	40	T5	T4	T4	T5	T5	T65	105
	55	T4A	T3C	T3C	T4	T4	T80	105
	65	T4A	T3C	T3C	T4	-	-	105

Drivers:

Option	FMVA3L-FMVA15L
/UNV1	NEC: 100-277 VAC, 50/60 Hz; 127-250 VDC; IEC: 100-240 VAC, 50/60 Hz; 127-250 VDC
/UNV34 ①	NEC/CEC only: 347-480 VAC, 50/60 Hz

Weights and dimensions:

Model	Lbs.	Kg.	Width		Height		Depth	
			in.	mm.	in.	mm.	in.	mm.
FMVA3L-FMVA15L	32.00	14.50	15.50	393.70	12.00	304.80	7.00	177.80

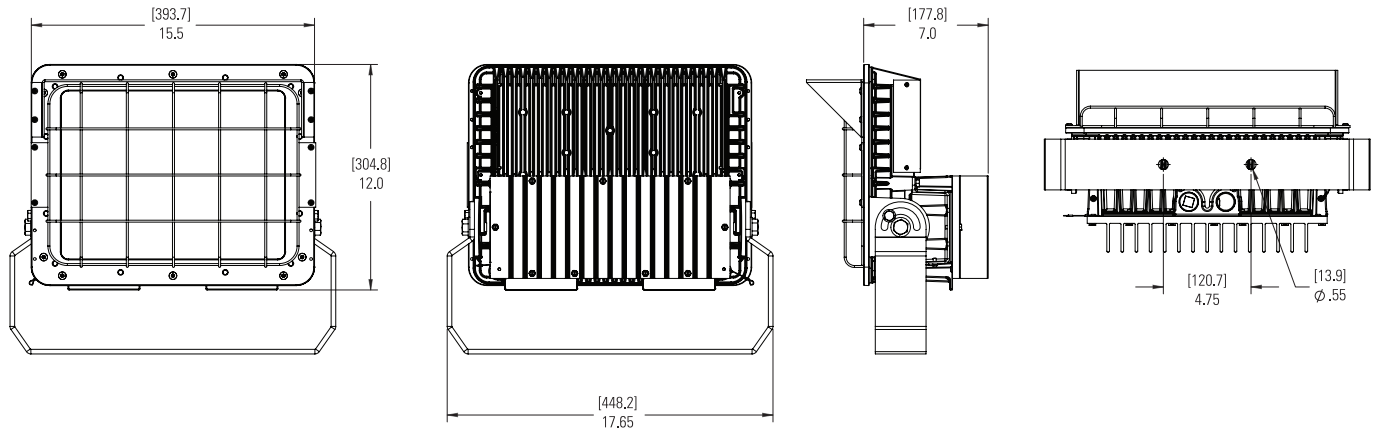

6L



Bogotá Sala de Ventas

Carrera 12 No 13 - 46
PBX: 6013360755 - 6013412439
Celular: 312 3055335

Centro de Distribución

Carrera 18 No 19A - 36
PBX: 6013360755 EXT: 2101

① UNV34 driver available for FMVA9L-15L only.

