

PORTUGUÊS	PG	ESPAÑOL	PG	ENGLISH	PG
ACESSÓRIOS	8	ACCESORIOS	8	ACCESSORIES	8
APRESENTAÇÃO	2	APRESENTACIÓN	2	ASSURANCE QUALITY	2
BARRAS DE COBRE	9-8	BARRA DE COBRE	9-8	AWG CODE EXAMPLE	4
BARRA DE TERRA	9-3	BARRA DE TIERRA	9-3	CONNECTIONS SYSTEMS	5 to 7
CABO DE COBRE	9-7	CABLE DE COBRE	9-7	CONVERSION FACTORS	10-2
CARACTERÍSTICAS ELÉTRICAS COBRE	10-1	CARACTERISTICAS ELECTRICAS DEL COBRE	10-1	COPPER BAR	9-8
CARACTERÍSTICAS ELÉTRICAS ALUMÍNIO	10-1	CARACTERISTICAS ELECTRICAS DEL ALUMINIO	10-1	COPPER CABLE	9-7
CARACTERÍSTICAS MECÂNICAS COBRE	10-1	CARACTERISTICAS MECANICAS DEL COBRE	10-1	COPPER CONDUCTORS	10-1
CARACTERÍSTICAS MECÂNICAS ALUMÍNIO	10-1	CARACTERISTICAS MECANICAS DEL ALUMINIO	10-1	CHARACTERISTICS	
CARACTERÍSTICAS TÉRMICAS COBRE	10-1	CARACTERISTICAS TERMICAS DEL COBRE	10-1	COPPER LUGS	9-6
CARACTERÍSTICAS TÉRMICAS ALUMÍNIO	10-1	CARACTERISTICAS TERMICAS DEL ALUMINIO	10-1	COPPER STRIP	9-8
COMO UTILIZAR O CATÁLOGO	3	COMO UTILIZAR EL CATALOGO	3	ELECTRICAL ALUMINIUM CHARACTERISTICS	10-1
CONDUTORES DE COBRE	10-5	CONDUTORES DE COBRE	10-5	ELECTRICAL COPPER CHARACTERISTICS	10-1
CONEXÕES EXOTÉRMICAS	5 a 7	CONEXIÓN EXOTERMICA	5 a 7	ELECTRICAL DATA CALCULATION	10-4
CONVERSÃO DE TEMPERATURA	10-3	CONVERSION DE TEMPERATURA	10-3	FASTGEL SOIL TREATMENT	9-9
CORDOALHA DE COBRE	9-13	EJEMPLOS DE CODIGOS mm2	2	GROUND ROD	9-12
EXEMPLO DE CÓDIGOS mm2	4	FACTORES DE CONVERSION	10-2	GROUND BAR	9-3
FATORES DE CONVERSÃO	10-2	FLEJE DE COBRE	9-8	HOW TO USE THIS CATALOG	3
FITAS DE COBRE	9-8	FASTGEL-TRATAMIENTO DEL SUELO	9-9	MECHANICAL ALUMINIUM CHARACTERISTICS	10-1
FASTGEL-TRATAMENTO DO SOLO	9-9	VARILLA DE TIERRA	9-12	MECHANICAL COPPER CHARACTERISTICS	10-1
HASTE DE ATERRAMENTO	9-12	MALLA PRE-FABRICADA	9-5	mm2 CODE EXAMPLE	4
MALHA PRÉ-FABRICADA	9-5	CALIDAD ASEGURADA	2	PRE FABRICATED GRID	9-5
PLACA DE ATERRAMENTO	9-4	SISTEMAS DE CONECCIONES	3	PRESENTATION	2
QUALIDADE ASSEGURADA	2	TABLA DE CALCULO ELETRICO	10-4	TEMPERATURE CONVERSION	10-3
SISTEMA DE CONEXÕES	3	TOMA TIERRA	9-4	THERMIC ALUMINIUM	10-1
TABELA CALCULO ELÉTRICO	10-4	TERMINALES DE COBRE	9-6	THERMIC COPPER	10-1
TERMINAIS DE COBRE	9-6	TRENZA DE COBRE	9-13		

CONEXÕES - CONEXIONES - CONNECTIONS	
B0	4-9
B1	4-1
B2	4-2
B3	4-3
B4	4-4
B5	4-5
B6	4-6
B7	4-7
B8	4-8
B9	4-8
G1	2-1
G1-H	3-2
G1-V	3-1
G2	2-2
G2-H	3-4
G2-V	3-3
G3	2-3
G4	2-4
G5	2-5
G6	2-6
G7	2-7
G8	2-7
G9	2-8
GG	2-6
H1	6-1
H2	6-1
H3	6-2
H4	6-3
H5	6-4
H6	6-4

ACESSÓRIOS - ACESORIOS - ACCESSORIES	
AC-32....AC-R	9-1
AF-1	9-1
AF-2	9-1
AF-3	9-1
AL-18	9-2
CF-1	9-1
CF-2	9-1
CF-3	9-1
CHF-4	9-2
CRH-18	9-1
ED-1...ED-R	9-1
EP-3	9-2
GC-7	9-2
GH-6	9-1
GM-3	9-1
GX	9-2
LA-3	9-2
LC-12	9-1
LC-34	9-1
LC-58	9-1
LI-2	9-2
LM-1	9-1
LM-2	9-1
LRT-2	9-2
MV-18	9-2
MV-18/2	9-2
OP-26	9-2
PLM-25	9-2
RA-32	9-1

**FASTWELD QUALIDADE
E SEGURANÇA PERMANENTE**

FASTWELD, UMA EMPRESA 100% BRASILEIRA APRESENTA SEU NOVO CATÁLOGO QUE IRÁ AJUDA-LO A ESPECIFICAR PRODUTOS PARA SISTEMAS DE PROTEÇÃO E ATERRAMENTO.

Fastweld é uma empresa formada por pessoas com mais de 25 anos de experiência. Nossos valores são:

**FASTWELD CALIDAD Y
SECURIDAD PERMANENTE**

FASTWELD UNA EMPRESA 100% BRASILEÑA PRESENTA SU NUEVO CATALOGO QUE LE AYUDARA A ESPECIFICAR PRODUCTOS PARA SISTEMAS DE PROTECCION Y PUESTA TIERRA.

Fastweld es una Compañia formada por personas con más de 25 años de experiencia. Nuestros valores son:

**FASTWELD A PERMANENT
SAFETY AND QUALITY**

FASTWELD, A 100% BRAZILIAN COMPANY, PRESENTS ITS NEW CATALOGUE WHICH WILL HELP YOU TO SPECIFY PRODUCTS FOR YOUR GROUNDING AND BONDING SYSTEM.

Fastweld is a company made by people with over 25 years of experience. Our values are:



Nossos produtos são reconhecidos e aprovados pelas maiores empresas de Engenharia e pelas mais importantes companhias de Energia, Telefonía, Ferrovia e Petróleo da América do Sul.

Nuestros productos son reconocidos y aprobados por las mas grandes Compañias de Ingenieria y por las mas importantes Empresas Electricas Telefonicas, Ferroviarias y Petroleras de Sudamerica.

Our products are recognized by its quality and are approved by the largest Brazilian and South American Engineering Companies and the most important Electrical, Telephone Railway and Petroleum Companies in South América.

**FASTWELD - QUALIDADE
ASSEGUADA**

A FASTWELD EFETUA ENSAIOS EM SEUS PRODUTOS PARA GARANTIR A QUALIDADE EXIGIDA.

SOLDA EXOTÉRMICA-IEEE-837

- RESISTÊNCIA ELÉTRICA
- CONDUTIVIDADE
- RESISTÊNCIA MECÂNICA
- CURTO CIRCUITO
- FORÇA ELETROMAGNÉTICA
- CORROSÃO

FASTGEL

- pH
- TOXIDEZ
- IRRITABILIDADE CUTÂNEA
- RESISTIVIDADE
- CORROSÃO

A FASTWELD ASSEGURA AOS CLIENTES TODO SUPORTE E ASSISTÊNCIA TÉCNICA NA APLICAÇÃO DE SEUS PRODUTOS.

**FASTWELD - CALIDAD
ASEGUADA**

FASTWELD EFECTUA ENSAYOS EN SUS PRODUCTOS PARA GARANTIZAR LA CALIDAD EXIGIDA.

SOLDADURA EXOTERMICA-IEEE-837

- RESISTENCIA ELECTRICA
- CONDUCTIVIDAD
- RESISTENCIA MECANICA
- CORTO CIRCUITO
- FUERZA ELECTROMAGNETICA
- CORROSION

FASTGEL

- pH
- TOXICIDAD
- IRRITABILIDAD CUTANEA
- RESISTIVIDAD
- CORROSIÓN

FASTWELD OFRECE Y BRINDA A SUS CLIENTES TODO EL SOPORTE Y ASISTENCIA TECNICA EN LA CORRECTA UTILIZACION DE SUS PRODUCTOS.

**FASTWELD QUALITY
ASSURANCE**

FASTWELD MAKES SEVERAL TESTS IN ORDER TO GUARANTEE THE QUALITY OF THE PRODUCT.

EXOTHERMIC WELD-IEEE-837

- ELECTRICAL RESISTANCE
- CONDUCTIVITY
- MECHANICAL RESISTANCE
- SHORT CIRCUIT
- ELECTROMAGNETIC FORCE
- CORROSION

FASTGEL

- pH
- TOXICOLOGICAL TESTS
- DHERMATOLOGIC TESTS
- RESISTIVITY
- CORROSION

FASTWELD ASSURES ASSISTANCE AND TECHNICAL SUPPORT FOR ALL FASTWELD PRODUCTS APLICATION

**FASTWELD SISTEMA DE
CONEXÕES**
**PARA EXECUTAR A CONEXÃO FASTWELD,
SERÁ NECESSÁRIO**

Molde - tem vida útil de 50 soldas
 Cartucho - (composto de solda) 1 para cada solda
 Alicate - um para cada 500 soldas
 Acendedor - um para cada 500 soldas
 E outros acessórios que você poderá encontrar na página 9 - 1 e 9 - 2

**FASTWELD SISTEMA DE
CONEXIONES**
**PARA HACER UNA CONEXIÓN FASTWELD
SERA NECESÁRIO**

Molde - vida util de 50 conexiones:
 Carga de Soldadura - (cuproaluminotérmica)
 un compuesto exotermico por cada conexion
 Manija (pinza) - una para 500 soldaduras
 Chispero - uno para 500 soldaduras
 Y otros accesorios que usted podra ver en las paginas 9 - 1 y 9 - 2

**FASTWELD
CONNECTIONS SYSTEMS**
**TO MAKE A FASTWELD CONNECTION YOU
WILL NEED**

Mould - make 50 welds
 Cartridge - (weld metal) used one by one weld
 Handle clamp - one to make 500 welds
 Flint gun - one to make 500 welds
 And some other accessories which you can find on pages 9 - 1 and 9 - 2

**COMO UTILIZAR ESTE
CATÁLOGO**

Você poderá selecionar o tipo de conexão nas páginas 5 a 7. A ilustração na página indicada, confirmará o tipo de conexão e a posição dos condutores. As tabelas que especificam moldes, cartuchos e acessórios são definidas por símbolos, os quais você poderá identificar na aba da capa do catálogo. Procure pelos condutores que você irá soldar e defina os materiais de solda. Em cada tabela você encontrará:

- Molde padrão Fastweld e o mini molde Fastweld. O mini molde é um padrão Brasileiro para soldas menores e mais econômicas, preservando as características elétricas do sistema.

- Cartucho Fastweld - Composto exotérmico

- Alicate

- Acessórios rerequeridos: são acessórios que obrigatoriamente você deverá utilizar para executar a solda

- Acessórios sugeridos: são acessórios que certamente facilitarão a aplicação do material e assim você obterá maior rendimento e uma solda melhor.

**COMO UTILIZAR ESTE
CATALOGO**

Usted podrá seleccionar el tipo de soldadura en la página 5 a 7 que muestra distintos tipos (figura) de conexión y la posición de los conductores (elementos a soldar). Las tablas que especificam los moldes, soldadura y accesorios están definidos por símbolos que identificarán los elementos como se puede apreciar en la oreja de la portada de nuestro catálogo.

Verifique los conductores a soldar y defina los materiales que se han de utilizar
 En la tablas usted encontrará:

- El molde standart Fastweld y el mini molde Fastweld. El mini molde és un padron Brasileiro para soldaduras pequeñas y mas economicas, que preserva las características eléctricas de el sistema.

- Soldadura Fastweld - Compuesto exotérmico

- Pinza ó Alicate

- Accesorios requeridos: son los que necesariamente deben utilizar-se para una buena ejecucion en la soldadura

- Accesorios sugeridos: son los que van a facilitar la aplicación de los materiales para un mayor rendimiento y una mejor calidad en la soldadura.

**HOW TO USE THIS
CATALOGUE**

You can select the type of connection that you want on page 5 to 7. On the mentioned page the illustration will confirm the connection type and the conductors for which is suitable. The fould out flap in front of the catalogue contains a key to the simbols used in the tables.

Search for the conductor size applicable and define the weld materials.

In each table you will find:

- Fastweld standart mould and the Fastweld mini Mould. The mini mould is a Brazilian standard for little and cheaper connections, preserving the electrical systems characteristics.

- Weld metal Fastweld - Exothermic compound

- Handle Clamps

- Required accessories - which you must use to make an exothermic weld

- Suggested accessories wich you will be able to make the connections in an easier way resulting in a better weld.

EXEMPLO DE CÓDIGO DE MOLDE FASTWELD
CABOS SISTEMA MÉTRICO (mm2)

EJEMPLO DE CODIGO DE MOLDE FASTWELD
CABLES SISTEMA MÉTRICO (mm2)

FASTWELD MOULD CODE EXAMPLE
METRIC SYSTEM CABLES (mm2)

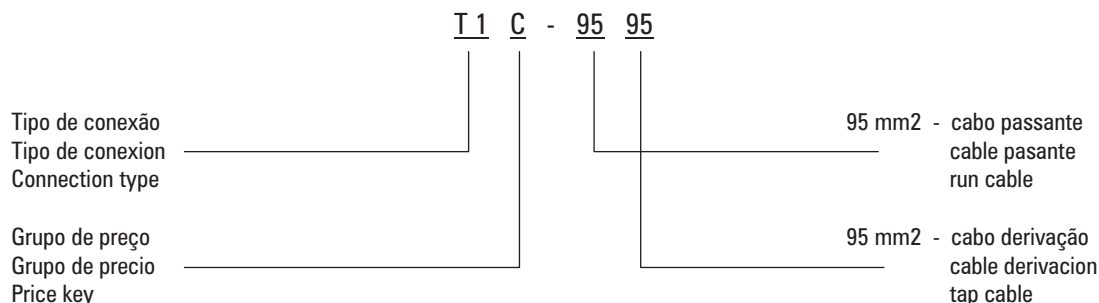

BITOLA DO CABO EM AWG/MCM	SECCIONES DEL CABLE AWG/MCM	AWG / MCM CABLE SIZE
---------------------------	-----------------------------	----------------------

Utilize a tabela da seção 9 página 9 - 7 e verifique a bitola de cabo equivalente em mm2. Especifique o código do molde em mm2 equivalente ao cabo em AWG e coloque ao lado do código a letra "A". Veja exemplo abaixo:

Vea la tabla en la sección 9, pagina 9-7 y verifique el calibre del cable en mm². Especifique el código del molde en mm² equivalente al cable en awg y coloque al lado del código la letra "A" Vea ejemplo a continuación:

See the technical table, section 9 page 9 - 7. Choose the equivalent cable in mm2. Specify the mould code equivalent in mm2 to the AWG cable and add the letter "A" after the cable code. See example as follow

EXEMPLO DE CÓDIGO DE MOLDE FASTWELD
CABOS SISTEMA AWG/MCM

EJEMPLO DE CODIGO DE MOLDE FASTWELD
CABLES SISTEMA AWG/MCM

FASTWELD MOULD CODE EXAMPLE
AWG/MCM SYSTEM CABLES

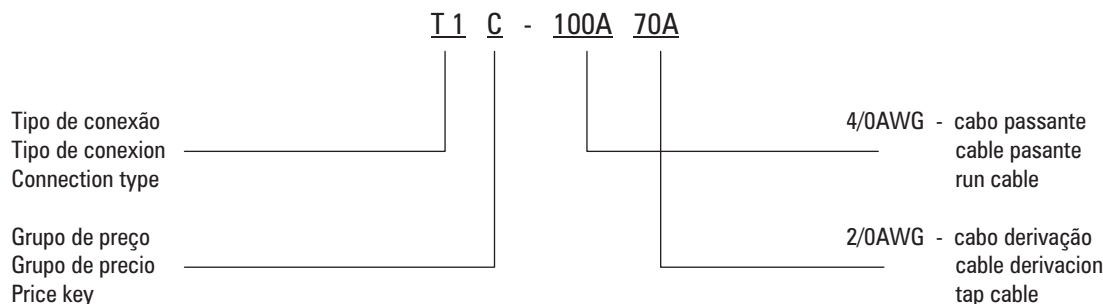

If you are using an AWG or MCM cable, find the equivalent cable in mm2 (page 9 - 7 Technical Information), choose the mould in mm2 equivalent and add the "A" letter after the cable code, for example:

"T1" connection between a 4/0AWG cable run, with a 2/0AWG cable tap. The equivalent cables are: 4/0 AWG 100mm2 and the 2/0 AWG equivalent is 70mm2 so, the mould code will be: T1C - 100A70A.

ÍNDICE FASTWELD



FASTWELD INDEX

SOLDAS EXOTÉRMICAS

SOLDADURA EXOTERMICAS

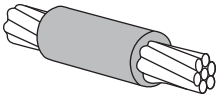
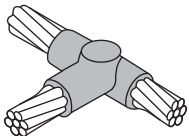
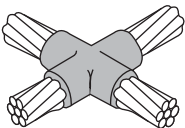
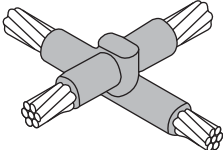
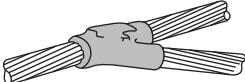
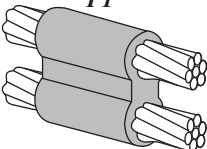
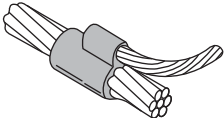
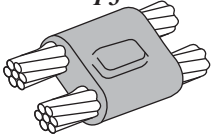
EXOTHERMIC WELD

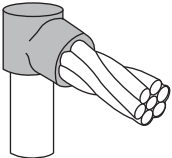
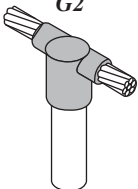
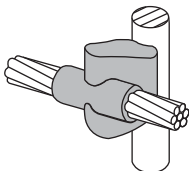
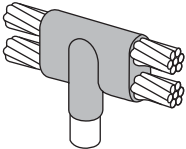
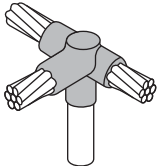
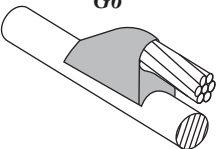
CABO COM CABO SEÇÃO 1	CABLE CON CABLE SECCIÓN 1	CABLE TO CABLE SECTION 1	
<i>S1</i> 	<i>T1</i> 	<i>X1</i> 	<i>X2</i> 
<i>Y1</i> 	<i>P1</i> 	<i>P2</i> 	<i>P3</i> 

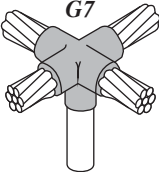
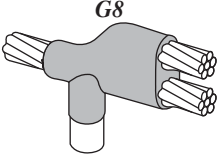
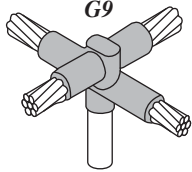
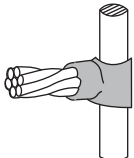
CABO COM HASTE SEÇÃO 2	CABLE CON VARILLA SECCIÓN 2	CABLE TO GROUND ROD SECTION 2			
<i>G1</i> 	<i>G2</i> 	<i>G3</i> 	<i>G4</i> 	<i>G5</i> 	
<i>G6</i> 	<i>GG</i> 	<i>G7</i> 	<i>G8</i> 	<i>G9</i> 	<i>G10</i> 

INDICE FASTWELD

FASTWELD INDEX

CONEXÃO FITA DE COBRE
A HASTE DE ATERRAMENTO
SEÇÃO 3

CONEXIÓN FLEJE DE COBRE A
VARILLA PUESTA TIERRA
SECCIÓN 3

COPPERTAPE TO
GROUND ROD
SECTION 3

G1 - H

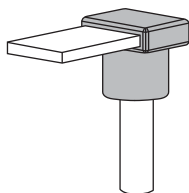

G1 - V

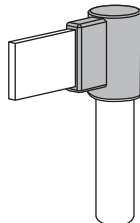

G2 - H

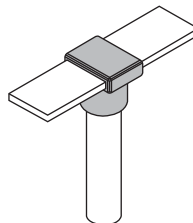

G2 - V

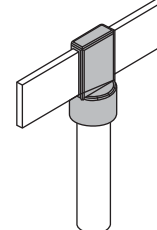

BARRA COM BARRA
SEÇÃO 4

BARRA CON BARRA
SECCIÓN 4

BAR TO BAR
SECTION 4

B1

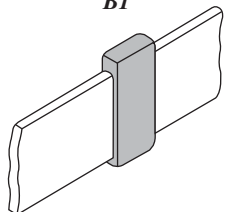

B2

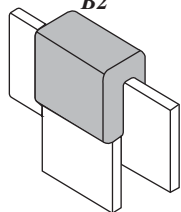

B3

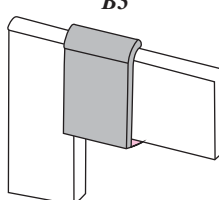

B4

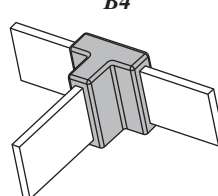

B5

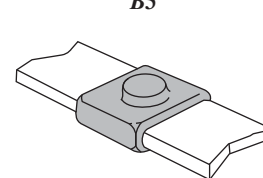

B6

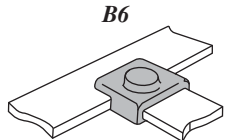

B7

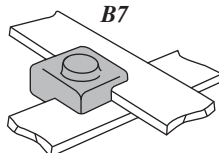

B8

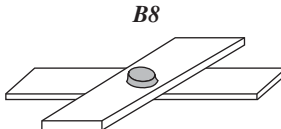

B9

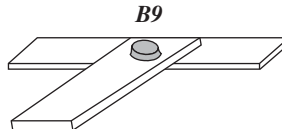

B0

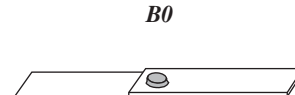

CABO A SUPERFICIE
VERTICAL
SEÇÃO 5

CABLE A SUPERFICIE
VERTICAL
SECCIÓN 5

CABLE TO VERTICAL
SURFACE
SECTION 5

V1

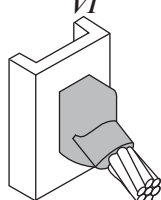

V3

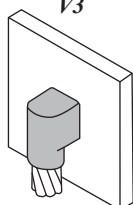

V4

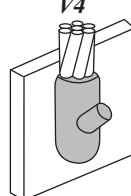

V5

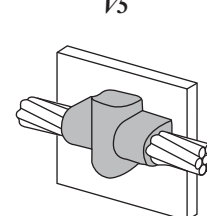

V6

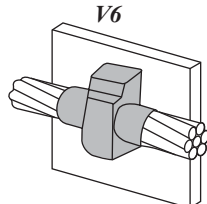

V7

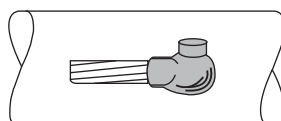

V8

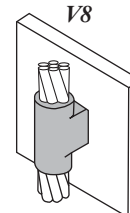

INDICE FASTWELD

FASTWELD INDEX

CABO A SUPERFÍCIE HORIZONTAL SEÇÃO 6	CABLE A SUPERFÍCIE HORIZONTAL SECCIÓN 6	CABLE TO HORIZONTAL SURFACE SECTION 6
--	---	---

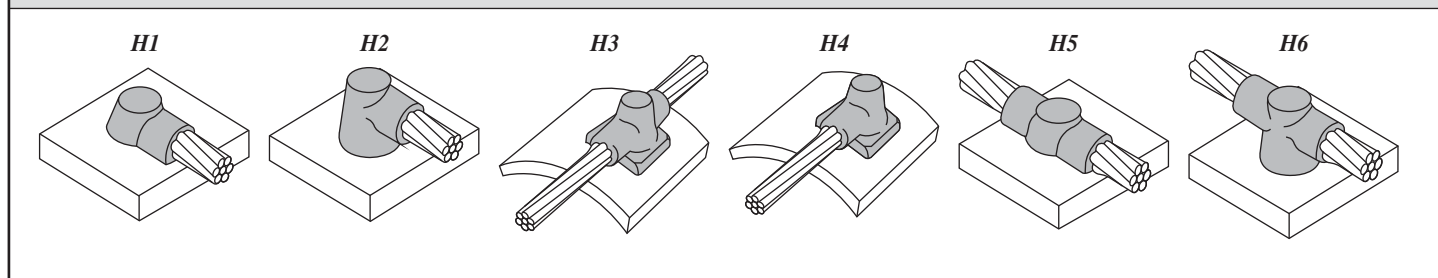

CABO A BARRA DE COBRE SEÇÃO 7	CABLE A BARRA DE COBRE SECCIÓN 7	CABLE TO COPPER BAR SECTION 7
----------------------------------	-------------------------------------	----------------------------------

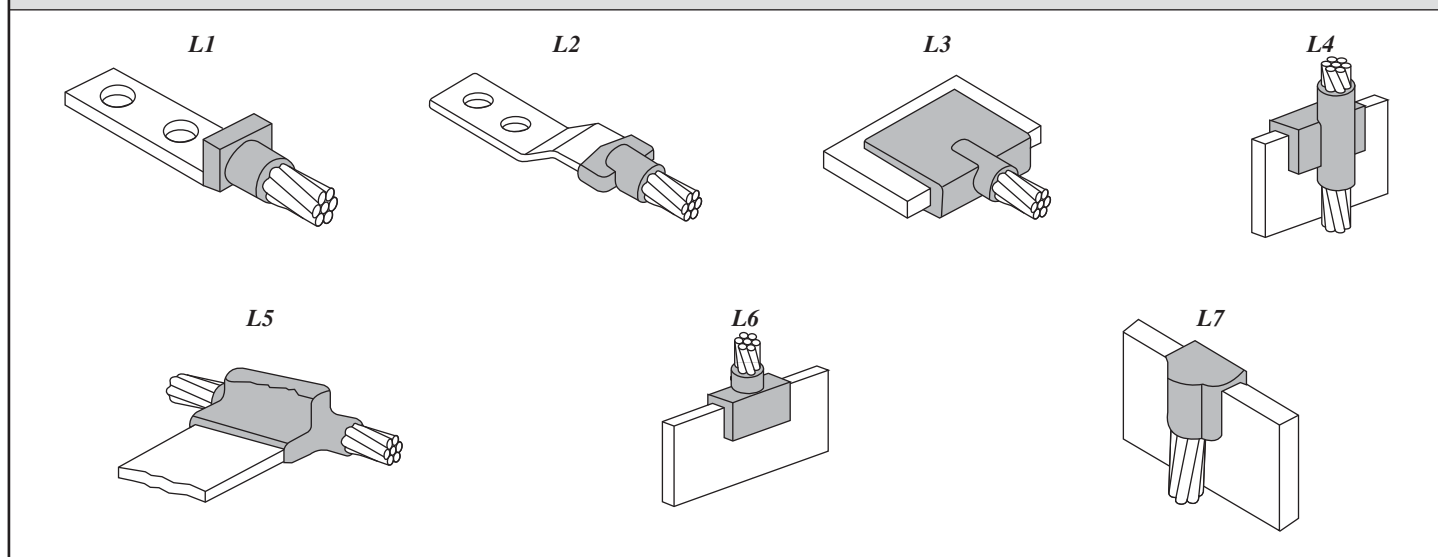

CABO A BARRA DE AÇO SEÇÃO 8	CABLE A BARRA DE ACERO SECCIÓN 8	CABLE TO REBAR SECTION 8
--------------------------------	-------------------------------------	-----------------------------

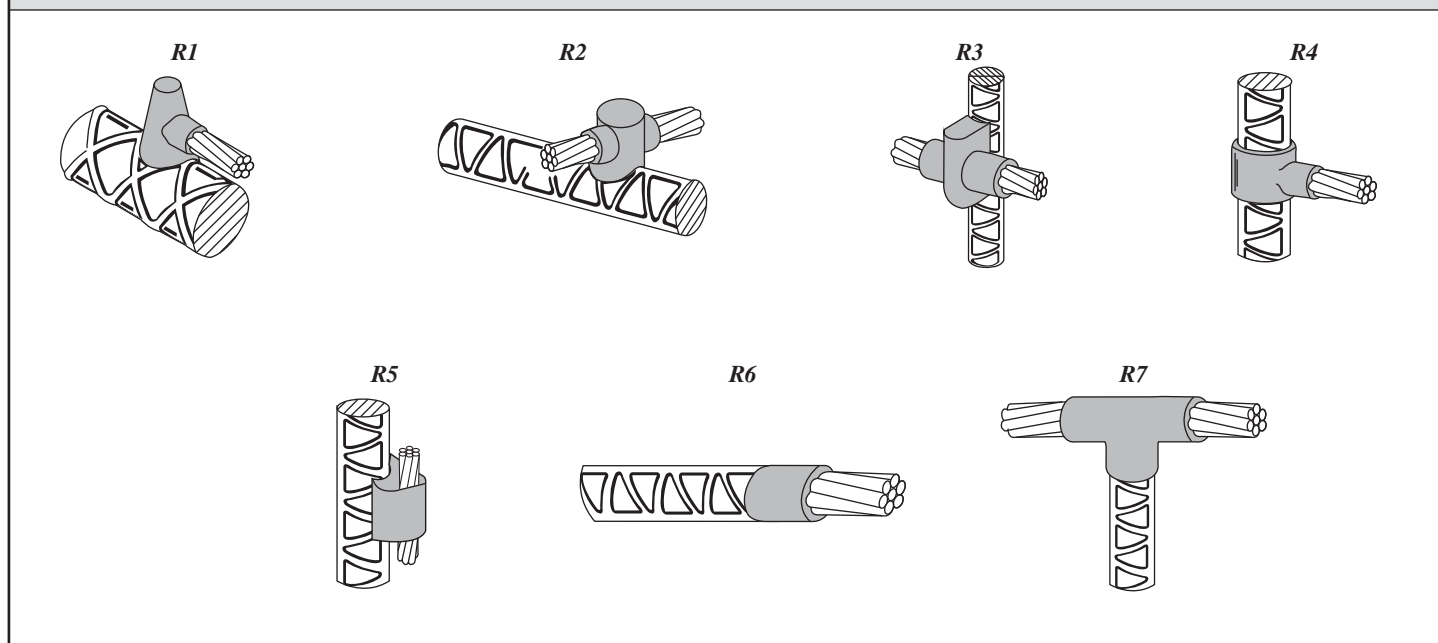

SEÇÃO 9

SECCIÓN 9

SECTION 9

BARRA EQUIPOTENCIAL
BARRA DE EQUIPOTENCIALIZACION
GROUND BAR



FASTGEL PARA BAIXAR A RESISTIVIDADE DO SOLO
FASTGEL PARA BAJAR LA RESISTIVIDAD DEL SUELO
FASTGEL TO REDUCE THE GROUND RESISTANCE

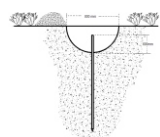

LAMINA E BARRA DE COBRE
FLEJE Y BARRA DE COBRE
STRIP AND COPPER BAR



PLACA DE ATERRAMENTO
TOMA TIERRA
GROUND PLATE

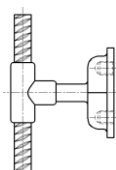

CORDOALHA DE ATERRAMENTO
TRENZA PARA PUESTA TIERRA
GROUND BRAID



HASTE DE ATERRAMENTO
BARRA PUESTA TIERRA
GROUND ROD

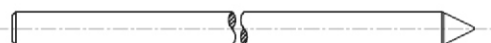

MALHA PRÉ FABRICADA
MALLA PRE FABRICADA
PRE FABRICATED GRID

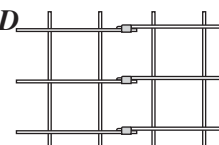

TERMINAIS DE COBRE
TERMINALES DE COBRE
COPPER LUGS

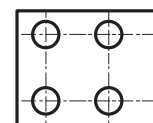

ACESSÓRIOS

ACCESÓRIOS

ACCESSORIES

SEÇÃO 9

SECCIÓN 9

SECTION 9

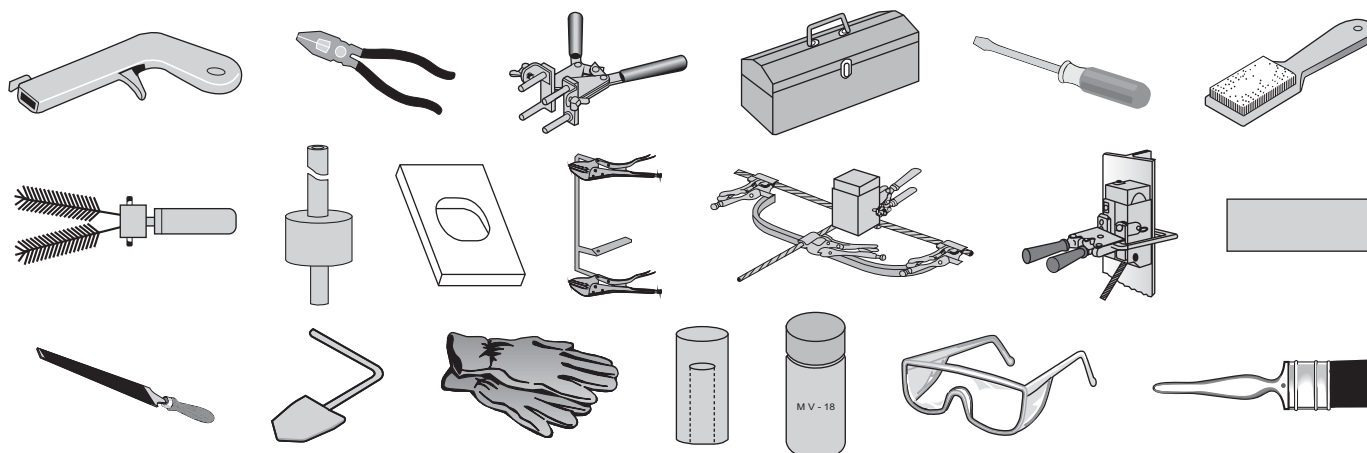

DADOS TÉCNICOS

DATOS TECNICOS

TECHNICAL DATA

SEÇÃO 10

SECCIÓN 10

SECTION 10

SEÇÃO
SECCIÓN
SECTION



CONEXÃO CABO A CABO

CONEXIÓN CABLE A CABLE

CABLE TO CABLE CONNECTION

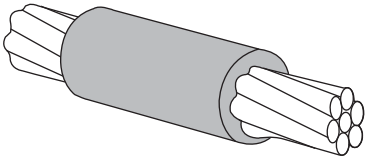
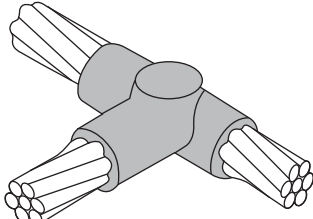
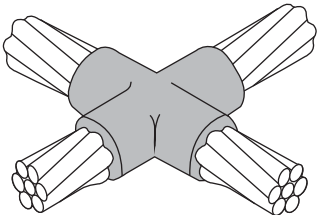
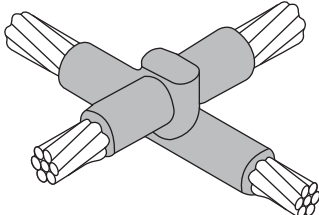
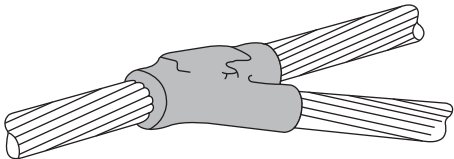
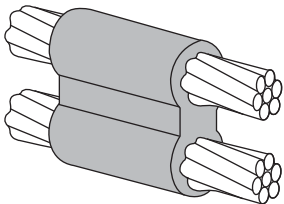
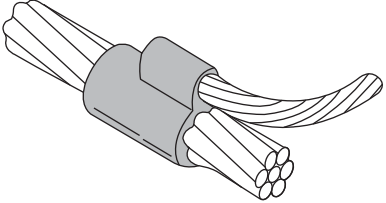
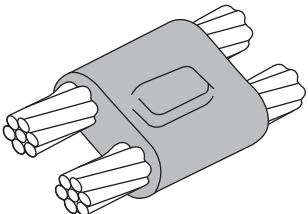
 <p><i>PÁG. 1 - 1</i></p>	<p>S1</p>  <p><i>PÁG. 1 - 2</i></p>
 <p><i>PÁG. 1 - 3</i></p>	<p>T1</p>  <p><i>PÁG. 1 - 4</i></p>
 <p><i>PÁG. 1 - 5</i></p>	<p>X1</p>  <p><i>PÁG. 1 - 5</i></p>
 <p><i>PÁG. 1 - 6</i></p>	<p>Y1</p> 







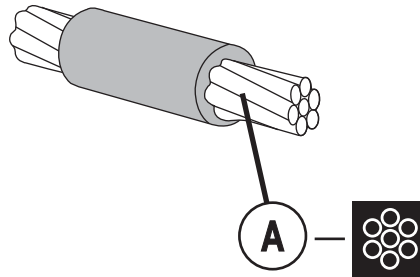

Bogotá Sala de Ventas

Carrera 12 No 13 - 46
PBX: 6013360755 - 6013412439
Celular: 312 3055335

Centro de Distribución

Carrera 18 No 19A - 36
PBX: 6013360755 EXT: 2101



A mm ²				MINI 		
10	S 1 C - 10	32.2L2	AF-2	S 1 B - 10	25	AF-1
16	S 1 C - 16	32.2L3	AF-2	S 1 B - 16	25	AF-1
25	S 1 C - 25	32	AF-2	S 1 B - 25	25	AF-1
35	S 1 C - 35	32	AF-2	S 1 B - 35	25	AF-1
50	S 1 C - 50	45	AF-2	S 1 B - 50	25	AF-1
70	S 1 C - 70	65	AF-2	S 1 B - 70	45	AF-1
95	S 1 C - 95	90	AF-2	-	-	-
100	S 1 C - 100	90	AF-2	-	-	-
120	S 1 C - 120	115	AF-2	-	-	-
150	S 1 C - 150	115	AF-2	-	-	-
185	S 1 C - 185	150	AF-2	-	-	-
240	S 1 C - 240	200	AF-2	-	-	-
300	S 1 C - 300	250	AF-2	-	-	-
400	S 1 D - 400	300	AF-3	-	-	-
500	S 1 D - 500	400	AF-3	-	-	-



= 1, 2

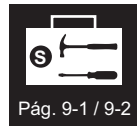

= 5, 15, 16, 17, 18

T1

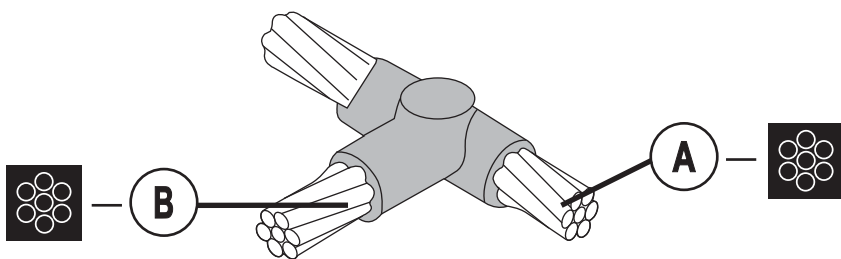

A mm ²	B mm ²				MINI 		
10	10	T 1 C - 10 10	45.3L2	AF-2	T 1 B - 10 10	25	AF-1
16	16	T 1 C - 16 16	45.3L3	AF-2	T 1 B - 16 16	25	AF-1
25	25	T 1 C - 25 25	45	AF-2	T 1 B - 25 25	25	AF-1
25	16	T 1 C - 25 16	45	AF-2	T 1 B - 25 16	25	AF-1
35	35	T 1 C - 35 35	45	AF-2	T 1 B - 35 35	32	AF-1
35	25	T 1 C - 35 25	45	AF-2	T 1 B - 35 25	32	AF-1
35	16	T 1 C - 35 16	45	AF-2	T 1 B - 35 16	32	AF-1
50	50	T 1 C - 50 50	90	AF-2	-	-	-
50	35	T 1 C - 50 35	65	AF-2	T 1 B - 50 35	32	AF-1
50	25	T 1 C - 50 25	65	AF-2	T 1 B - 50 25	32	AF-1
50	16	T 1 C - 50 16	65	AF-2	T 1 B - 50 16	32	AF-1
70	70	T 1 C - 70 70	90	AF-2	-	-	-
70	50	T 1 C - 70 50	90	AF-2	-	-	-
70	35	T 1 C - 70 35	65	AF-2	T 1 B - 70 35	32	AF-1
70	25	T 1 C - 70 25	65	AF-2	T 1 B - 70 25	32	AF-1
95	95	T 1 C - 95 95	115	AF-2	-	-	-
95	70	T 1 C - 95 70	90	AF-2	-	-	-
95	50	T 1 C - 95 50	90	AF-2	-	-	-
95	35	T 1 C - 95 35	90	AF-2	T 1 B - 95 35	32	AF-1
95	25	T 1 C - 95 25	90	AF-2	T 1 B - 95 25	32	AF-1
100	100	T 1 C - 100 100	150	AF-2	-	-	-
100	95	T 1 C - 100 95	115	AF-2	-	-	-
100	70	T 1 C - 100 70	90	AF-2	-	-	-
100	50	T 1 C - 100 50	90	AF-2	-	-	-
100	35	T 1 C - 100 35	90	AF-2	-	-	-
120	120	T 1 C - 120 120	150	AF-2	-	-	-
120	100	T 1 C - 120 100	150	AF-2	-	-	-
120	95	T 1 C - 120 95	150	AF-2	-	-	-
120	70	T 1 C - 120 70	90	AF-2	-	-	-
120	50	T 1 C - 120 50	90	AF-2	-	-	-
120	35	T 1 C - 120 35	90	AF-2	-	-	-
120	25	T 1 C - 120 25	90	AF-2	-	-	-
150	150	T 1 C - 150 150	200	AF-2	-	-	-
150	120	T 1 C - 150 120	150	AF-2	-	-	-
150	100	T 1 C - 150 100	150	AF-2	-	-	-
150	95	T 1 C - 150 95	150	AF-2	-	-	-
150	70	T 1 C - 150 70	90	AF-2	-	-	-
185	185	T 1 C - 185 185	200	AF-2	-	-	-
185	150	T 1 C - 185 150	200	AF-2	-	-	-
185	120	T 1 C - 185 120	200	AF-2	-	-	-
185	100	T 1 C - 185 100	150	AF-2	-	-	-
185	95	T 1 C - 185 95	150	AF-2	-	-	-
240	240	T 1 C - 240 240	300	AF-2	-	-	-
240	185	T 1 C - 240 185	200	AF-2	-	-	-
240	150	T 1 C - 240 150	200	AF-2	-	-	-
240	120	T 1 C - 240 120	200	AF-2	-	-	-
240	100	T 1 C - 240 100	200	AF-2	-	-	-
300	300	T 1 D - 300 300	400	AF-3	-	-	-
300	240	T 1 D - 300 240	400	AF-3	-	-	-
300	185	T 1 C - 300 185	250	AF-2	-	-	-
300	150	T 1 C - 300 150	250	AF-2	-	-	-



= 1, 2



= 5, 15, 16, 17, 18

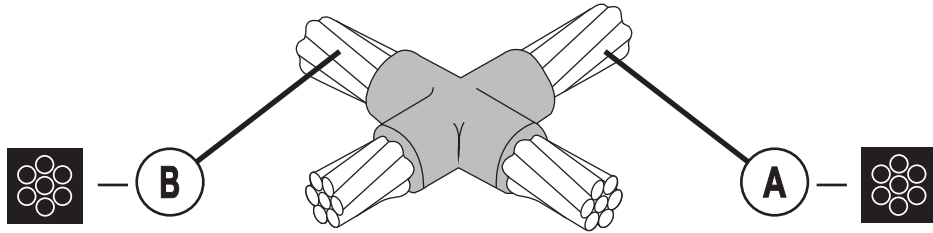

A mm ²	B mm ²				MINI 		
10	10	X 1 C - 10 10	45.4L2	AF-2	X 1 B - 10 10	32	AF-1
16	16	X 1 C - 16 16	45.4L3	AF-2	X 1 B - 16 16	32	AF-1
25	25	X 1 C - 25 25	45	AF-2	X 1 B - 25 25	32	AF-1
25	16	X 1 C - 25 16	45.L3	AF-2	X 1 B - 25 16	32	AF-1
35	35	X 1 C - 35 35	65	AF-2	X 1 B - 35 35	45	AF-1
35	25	X 1 C - 35 25	65	AF-2	X 1 B - 35 25	45	AF-1
35	16	X 1 C - 35 16	65.2L3	AF-2	X 1 B - 35 16	45	AF-1
50	50	X 1 C - 50 50	90	AF-2	-	-	-
50	35	X 1 C - 50 35	90	AF-2	-	-	-
50	25	X 1 C - 50 25	90	AF-2	-	-	-
70	70	X 1 C - 70 70	115	AF-2	-	-	-
70	50	X 1 C - 70 50	115	AF-2	-	-	-
70	35	X 1 C - 70 35	115	AF-2	-	-	-
95	95	X 1 C - 95 95	150	AF-2	-	-	-
95	70	X 1 C - 95 70	150	AF-2	-	-	-
95	50	X 1 C - 95 50	115	AF-2	-	-	-
95	35	X 1 C - 95 35	115	AF-2	-	-	-
100	100	X 1 C - 100 100	200	AF-2	-	-	-
100	95	X 1 C - 100 95	200	AF-2	-	-	-
100	70	X 1 C - 100 70	150	AF-2	-	-	-
100	50	X 1 C - 100 50	150	AF-2	-	-	-
100	35	X 1 C - 100 35	115	AF-2	-	-	-
120	120	X 1 C - 120 120	200	AF-2	-	-	-
120	100	X 1 C - 120 100	200	AF-2	-	-	-
120	95	X 1 C - 120 95	200	AF-2	-	-	-
120	70	X 1 C - 120 70	150	AF-2	-	-	-
120	50	X 1 C - 120 50	150	AF-2	-	-	-
120	35	X 1 C - 120 35	115	AF-2	-	-	-
150	150	X 1 C - 150 150	250	AF-2	-	-	-
150	120	X 1 C - 150 120	250	AF-2	-	-	-
150	100	X 1 C - 150 100	200	AF-2	-	-	-
150	95	X 1 C - 150 95	200	AF-2	-	-	-
150	70	X 1 C - 150 70	150	AF-2	-	-	-
150	50	X 1 C - 150 50	150	AF-2	-	-	-
150	35	X 1 C - 150 35	115	AF-2	-	-	-
185	185	X 1 C - 185 185	250	AF-2	-	-	-
185	150	X 1 C - 185 150	250	AF-2	-	-	-
185	120	X 1 C - 185 120	250	AF-2	-	-	-
185	100	X 1 C - 185 100	200	AF-2	-	-	-
185	95	X 1 C - 185 95	200	AF-2	-	-	-
185	70	X 1 C - 185 70	200	AF-2	-	-	-
185	50	X 1 C - 185 50	200	AF-2	-	-	-
240	240	X 1 D - 240 240	500	AF-3	-	-	-
240	185	X 1 D - 240 185	400	AF-3	-	-	-
240	150	X 1 D - 240 150	400	AF-3	-	-	-
240	120	X 1 D - 240 120	300	AF-3	-	-	-
240	100	X 1 C - 240 100	300	AF-3	-	-	-
240	95	X 1 D - 240 95	300	AF-3	-	-	-
240	70	X 1 C - 240 70	250	AF-2	-	-	-
240	50	X 1 C - 240 50	250	AF-2	-	-	-



= 1, 2



= 5, 11, 15, 16, 17, 18

X2

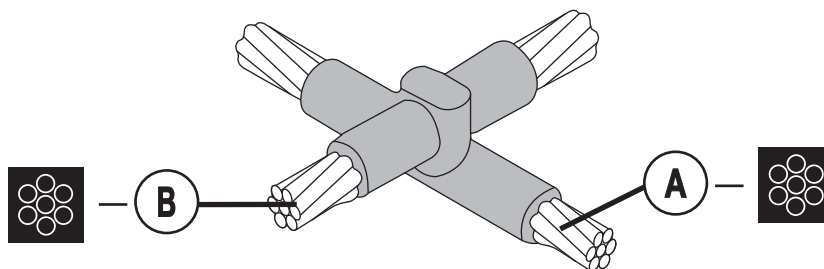

A mm ²	B mm ²				MINI 		
10	10	X 2 C - 10 10	45	AF-2	X 2 B - 10 10	45	AF-1
16	16	X 2 C - 16 16	45	AF-2	X 2 B - 16 16	45	AF-1
25	25	X 2 C - 25 25	65	AF-2	X 2 B - 25 25	45	AF-1
25	16	X 2 C - 25 16	65	AF-2	X 2 B - 25 16	45	AF-1
35	35	X 2 C - 35 35	90	AF-2	-	-	-
35	25	X 2 C - 35 25	65	AF-2	X 2 B - 35 25	45	AF-1
35	16	X 2 C - 35 16	65	AF-2	X 2 B - 35 16	45	AF-1
50	50	X 2 C - 50 50	150	AF-2	-	-	-
50	35	X 2 C - 50 35	115	AF-2	-	-	-
50	25	X 2 C - 50 25	115	AF-2	-	-	-
50	16	X 2 C - 50 16	115	AF-2	-	-	-
70	70	X 2 C - 70 70	200	AF-2	-	-	-
70	50	X 2 C - 70 50	200	AF-2	-	-	-
70	35	X 2 C - 70 35	150	AF-2	-	-	-
70	25	X 2 C - 70 25	150	AF-2	-	-	-
95	95	X 2 C - 95 95	250	AF-2	-	-	-
95	70	X 2 C - 95 70	200	AF-2	-	-	-
95	50	X 2 C - 95 50	200	AF-2	-	-	-
95	35	X 2 C - 95 35	150	AF-2	-	-	-
95	25	X 2 C - 95 25	150	AF-2	-	-	-
100	100	X 2 C - 100 100	250	AF-2	-	-	-
100	95	X 2 C - 100 95	250	AF-2	-	-	-
100	70	X 2 C - 100 70	200	AF-2	-	-	-
100	50	X 2 C - 100 50	200	AF-2	-	-	-
100	35	X 2 C - 100 35	150	AF-2	-	-	-
120	120	X 2 M - 120 120	300	-	-	-	-
120	100	X 2 M - 120 100	300	-	-	-	-
120	95	X 2 M - 120 95	300	-	-	-	-
120	70	X 2 C - 120 70	250	AF-2	-	-	-
120	50	X 2 C - 120 50	250	AF-2	-	-	-
120	35	X 2 C - 120 35	150	AF-2	-	-	-
120	25	X 2 C - 120 25	150	AF-2	-	-	-
150	150	X 2 V - 150 150	400	-	-	-	-
150	120	X 2 V - 150 120	400	-	-	-	-
150	100	X 2 M - 150 100	300	-	-	-	-
150	95	X 2 M - 150 95	300	-	-	-	-
150	70	X 2 M - 150 70	250	-	-	-	-
185	185	X 2 V - 185 185	500	-	-	-	-
185	150	X 2 V - 185 150	500	-	-	-	-
185	120	X 2 V - 185 120	500	-	-	-	-
185	100	X 2 V - 185 100	400	-	-	-	-
185	95	X 2 V - 185 95	400	-	-	-	-
185	70	X 2 V - 185 70	300	-	-	-	-
240	240	X 2 V - 240 240	750	-	-	-	-
240	185	X 2 V - 240 185	600	-	-	-	-
240	150	X 2 V - 240 150	600	-	-	-	-
240	120	X 2 V - 240 120	500	-	-	-	-
240	100	X 2 V - 240 100	500	-	-	-	-
240	95	X 2 V - 240 95	500	-	-	-	-
240	70	X 2 V - 240 70	400	-	-	-	-

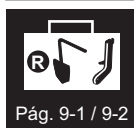

= 1, 2



= 5, 11, 15, 16, 17, 18

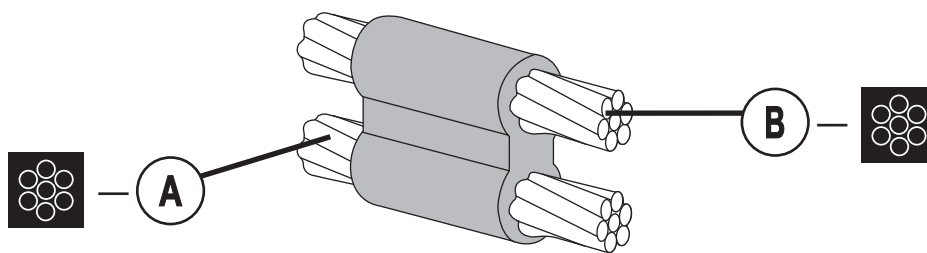

A mm ²	B mm ²				MINI 		
10	10	P 1 C - 10 10	45	AF-2	P 1 B -10 10	25	AF-1
16	16	P 1 C - 16 16	45	AF-2	P 1 B -16 16	25	AF-1
25	25	P 1 C - 25 25	45	AF-2	P 1 B -25 25	25	AF-1
25	16	P 1 C - 25 16	45	AF-2	P 1 B -25 16	25	AF-1
35	35	P 1 C - 35 35	65	AF-2	P 1 B -35 35	45	AF-1
35	25	P 1 C - 35 25	65	AF-2	P 1 B -35 25	45	AF-1
35	16	P 1 C - 35 16	65	AF-2	P 1 B -35 16	25	AF-1
50	50	P 1 C - 50 50	90	AF-2	-	-	-
50	35	P 1 C - 50 35	90	AF-2	P 1 B -50 35	45	AF-1
50	25	P 1 C - 50 25	65	AF-2	P 1 B -50 25	45	AF-1
50	16	P 1 C - 50 16	45	AF-2	P 1 B -50 16	32	AF-1
70	70	P 1 C - 70 70	115	AF-2	-	-	-
70	50	P 1 C - 70 50	115	AF-2	-	-	-
70	35	P 1 C - 70 35	90	AF-2	-	-	-
70	25	P 1 C - 70 25	90	AF-2	-	-	-
95	95	P 1 C - 95 95	150	AF-2	-	-	-
95	70	P 1 C - 95 70	150	AF-2	-	-	-
95	50	P 1 C - 95 50	115	AF-2	-	-	-
95	35	P 1 C - 95 35	115	AF-2	-	-	-
95	25	P 1 C - 95 25	115	AF-2	-	-	-
100	100	P 1 C - 100 100	200	AF-2	-	-	-
100	95	P 1 C - 100 95	200	AF-2	-	-	-
100	70	P 1 C - 100 70	115	AF-2	-	-	-
100	50	P 1 C - 100 50	115	AF-2	-	-	-
100	35	P 1 C - 100 35	115	AF-2	-	-	-
100	25	P 1 C - 100 25	115	AF-2	-	-	-
120	120	P 1 C - 120 120	250	AF-2	-	-	-
120	100	P 1 C - 120 100	200	AF-2	-	-	-
120	95	P 1 C - 120 95	150	AF-2	-	-	-
120	70	P 1 C - 120 70	150	AF-2	-	-	-
120	50	P 1 C - 120 50	150	AF-2	-	-	-
150	150	P 1 D - 150 150	250	AF-2	-	-	-
150	120	P 1 C - 150 120	200	AF-2	-	-	-
150	100	P 1 C - 150 100	200	AF-2	-	-	-
150	95	P 1 C - 150 95	200	AF-2	-	-	-
150	70	P 1 C - 150 70	150	AF-2	-	-	-
185	185	P 1 D - 185 185	300	AF-3	-	-	-
185	150	P 1 D - 185 150	300	AF-3	-	-	-
185	120	P 1 C - 185 120	250	AF-2	-	-	-
185	100	P 1 C - 185 100	200	AF-2	-	-	-
185	95	P 1 C - 185 95	200	AF-2	-	-	-
240	95	P 1 C - 240 95	200	AF-2	-	-	-
240	240	P 1 D - 240 240	400	AF-3	-	-	-
240	185	P 1 D - 240 185	300	AF-3	-	-	-
240	150	P 1 D - 240 150	300	AF-3	-	-	-
240	120	P 1 C - 240 120	250	AF-2	-	-	-
240	100	P 1 C - 240 100	250	AF-2	-	-	-
300	300	P 1 D - 300 300	500	AF-3	-	-	-
300	240	P 1 D - 300 240	500	AF-3	-	-	-
300	185	P 1 D - 300 185	400	AF-3	-	-	-
300	150	P 1 D - 300 150	300	AF-3	-	-	-







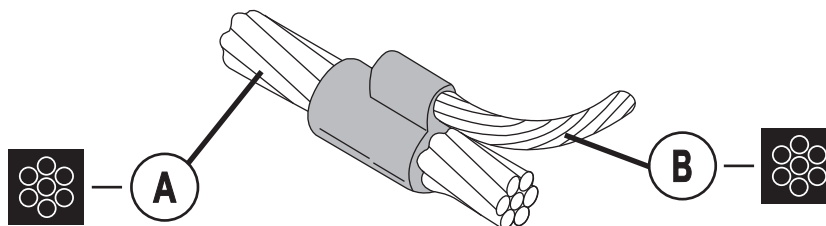

= 1, 2



= 5, 15, 16, 17, 18



A mm ²	B mm ²				MINI 		
10	10	P 2 C - 10 10	45	AF-2	P 2 B - 10 10	25	AF-1
16	16	P 2 C - 16 16	45	AF-2	P 2 B - 16 16	25	AF-1
25	25	P 2 C - 25 25	45	AF-2	P 2 B - 25 25	25	AF-1
25	16	P 2 C - 25 16	45	AF-2	P 2 B - 25 16	25	AF-1
35	35	P 2 C - 35 35	65	AF-2	P 2 B - 35 35	45	AF-1
35	25	P 2 C - 35 25	65	AF-2	P 2 B - 35 25	32	AF-1
35	16	P 2 C - 35 16	65	AF-2	P 2 B - 35 16	25	AF-1
50	50	P 2 C - 50 50	90	AF-2	-	-	-
50	35	P 2 C - 50 35	65	AF-2	P 2 B - 50 35	45	AF-1
50	25	P 2 C - 50 25	65	AF-2	P 2 B - 50 25	45	AF-1
50	16	P 2 C - 50 16	65	AF-2	P 2 B - 50 16	32	AF-1
70	70	P 2 C - 70 70	115	AF-2	-	-	-
70	50	P 2 C - 70 50	115	AF-2	-	-	-
70	35	P 2 C - 70 35	90	AF-2	-	-	-
70	25	P 2 C - 70 25	90	AF-2	P 2 B - 70 25	45	AF-1
95	95	P 2 C - 95 95	150	AF-2	-	-	-
95	70	P 2 C - 95 70	115	AF-2	-	-	-
95	50	P 2 C - 95 50	115	AF-2	-	-	-
95	35	P 2 C - 95 35	115	AF-2	-	-	-
95	25	P 2 C - 95 25	115	AF-2	-	-	-
100	100	P 2 C - 100 100	150	AF-2	-	-	-
100	95	P 2 C - 100 95	150	AF-2	-	-	-
100	70	P 2 C - 100 70	115	AF-2	-	-	-
100	50	P 2 C - 100 50	115	AF-2	-	-	-
100	35	P 2 C - 100 35	115	AF-2	-	-	-
100	25	P 2 C - 100 25	115	AF-2	-	-	-
120	120	P 2 C - 120 120	200	AF-2	-	-	-
120	100	P 2 C - 120 100	200	AF-2	-	-	-
120	95	P 2 C - 120 95	200	AF-2	-	-	-
120	70	P 2 C - 120 70	150	AF-2	-	-	-
120	50	P 2 C - 120 50	115	AF-2	-	-	-
120	35	P 2 C - 120 35	115	AF-2	-	-	-
120	25	P 2 C - 120 25	115	AF-2	-	-	-



= 1, 2



= 5, 15, 16, 17, 18



SEÇÃO
SECCIÓN
SECTION

2

CONEXÃO CABO A HASTE

CONEXIÓN CABLE A VARILLA

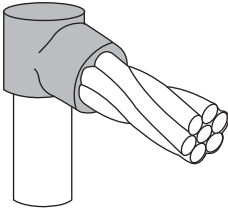
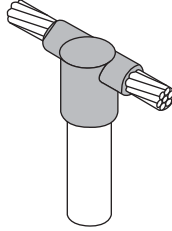
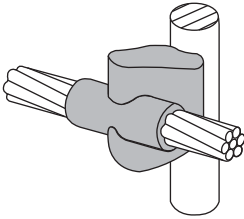
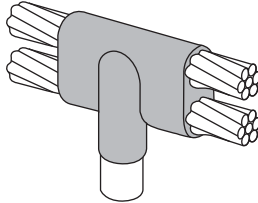
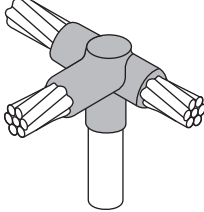
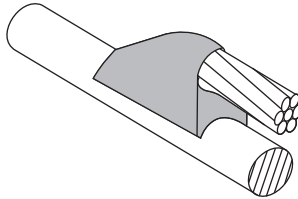
CABLE TO GROUND ROD CONNECTION

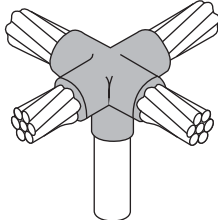
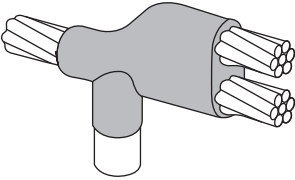
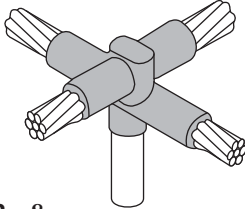
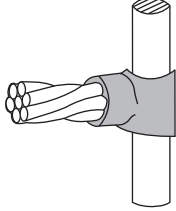
<p>G1</p>  <p><i>PÁG. 2 - 1</i></p>	<p>G2</p>  <p><i>PÁG. 2 - 2</i></p>	
<p>G3</p>  <p><i>PÁG. 2 - 3</i></p>	<p>G4</p>  <p><i>PÁG. 2 - 4</i></p>	
<p>G5</p>  <p><i>PÁG. 2 - 5</i></p>	<p>G6</p>  <p><i>PÁG. 2 - 6</i></p>	
<p>GG</p>  <p><i>PÁG. 2 - 6</i></p>	<p>G7</p>  <p><i>PÁG. 2 - 7</i></p>	
<p>G8</p>  <p><i>PÁG. 2 - 7</i></p>	<p>G9</p>  <p><i>PÁG. 2 - 8</i></p>	<p>G10</p>  <p><i>PÁG. 2 - 9</i></p>







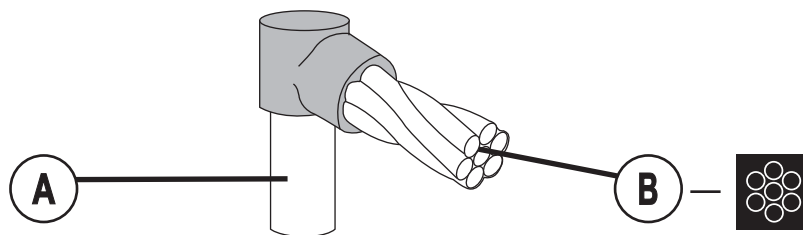

Bogotá Sala de Ventas

Carrera 12 No 13 - 46
PBX: 6013360755 - 6013412439
Celular: 312 3055335

Centro de Distribución

Carrera 18 No 19A - 36
PBX: 6013360755 EXT: 2101



A Ø	B mm ²				MINI 		
1/2" 12,8mm	10	G 1 C - 12 10	65	AF-2	G 1 B - 12 10	45	AF-1
	16	G 1 C - 12 16	65	AF-2	G 1 B - 12 16	65	AF-1
	25	G 1 C - 12 25	65	AF-2	G 1 B - 12 25	65	AF-1
	35	G 1 C - 12 35	65	AF-2	G 1 B - 12 35	65	AF-1
	50	G 1 C - 12 50	90	AF-2	G 1 B - 12 50	65	AF-1
	70	G 1 C - 12 70	90	AF-2	-	-	-
	95	G 1 C - 12 95	90	AF-2	-	-	-
	100	G 1 C - 12 100	90	AF-2	-	-	-
5/8" 14,3mm	16	G 1 C - 58 16	65	AF-2	G 1 B - 58 16	65	AF-1
	25	G 1 C - 58 25	65	AF-2	G 1 B - 58 25	65	AF-1
	35	G 1 C - 58 35	65	AF-2	G 1 B - 58 35	65	AF-1
	50	G 1 C - 58 50	90	AF-2	-	-	-
	70	G 1 C - 58 70	90	AF-2	-	-	-
	95	G 1 C - 58 95	90	AF-2	-	-	-
	100	G 1 C - 58 100	90	AF-2	-	-	-
	120	G 1 C - 58 120	90	AF-2	-	-	-
	150	G 1 C - 58 150	115	AF-2	-	-	-
	185	G 1 C - 58 185	115	AF-2	-	-	-
240	G 1 C - 58 240	150	AF-2	-	-	-	
3/4" 17,3mm	16	G 1 C - 34 16	65	AF-2	-	-	-
	25	G 1 C - 34 25	90	AF-2	-	-	-
	35	G 1 C - 34 35	90	AF-2	-	-	-
	50	G 1 C - 34 50	90	AF-2	-	-	-
	70	G 1 C - 34 70	90	AF-2	-	-	-
	95	G 1 C - 34 95	90	AF-2	-	-	-
	100	G 1 C - 34 100	90	AF-2	-	-	-
	120	G 1 C - 34 120	90	AF-2	-	-	-
	150	G 1 C - 34 150	115	AF-2	-	-	-
	185	G 1 C - 34 185	115	AF-2	-	-	-
	240	G 1 C - 34 240	150	AF-2	-	-	-
	300	G 1 C - 34 300	200	AF-2	-	-	-







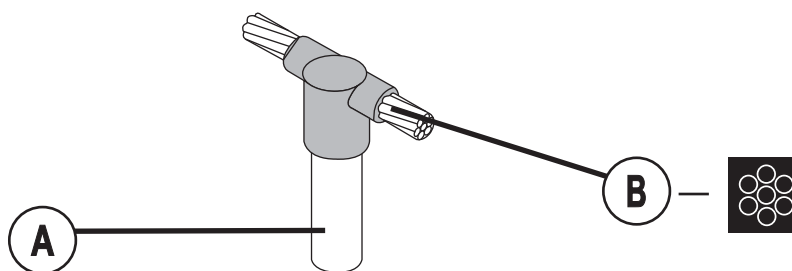

= 1, 2, 8



= 5, 15, 16, 17, 18



A Ø	B mm ²				MINI 		
1/2" 12,8mm	10	G 2 C - 12 10	65	AF-2	G 2 B - 12 10	65	AF-1
	16	G 2 C - 12 16	65	AF-2	G 2 B - 12 16	65	AF-1
	25	G 2 C - 12 25	90	AF-2	G 2 B - 12 25	65	AF-1
	35	G 2 C - 12 35	90	AF-2	G 2 B - 12 35	65	AF-1
	50	G 2 C - 12 50	90	AF-2	G 2 B - 12 50	65	AF-1
	70	G 2 C - 12 70	90	AF-2	-	-	-
	95	G 2 C - 12 95	115	AF-2	-	-	-
	100	G 2 C - 12 100	115	AF-2	-	-	-
5/8" 14,3mm	16	G 2 C - 58 16	65	AF-2	G 2 B- 58 16	65	AF-1
	25	G 2 C - 58 25	90	AF-2	G 2 B- 58 25	65	AF-1
	35	G 2 C - 58 35	90	AF-2	G 2 B- 58 35	65	AF-1
	50	G 2 C - 58 50	90	AF-2	-	-	-
	70	G 2 C - 58 70	115	AF-2	-	-	-
	95	G 2 C - 58 95	115	AF-2	-	-	-
	100	G 2 C - 58 100	115	AF-2	-	-	-
	120	G 2 C - 58 120	150	AF-2	-	-	-
	150	G 2 C - 58 150	200	AF-2	-	-	-
	185	G 2 C - 58 185	200	AF-2	-	-	-
240	G 2 C - 58 240	250	AF-2	-	-	-	
3/4" 17,3mm	16	G 2 C - 34 16	90	AF-2	-	-	-
	25	G 2 C - 34 25	90	AF-2	-	-	-
	35	G 2 C - 34 35	90	AF-2	-	-	-
	50	G 2 C - 34 50	115	AF-2	-	-	-
	70	G 2 C - 34 70	115	AF-2	-	-	-
	95	G 2 C - 34 95	115	AF-2	-	-	-
	100	G 2 C - 34 100	115	AF-2	-	-	-
	120	G 2 C - 34 120	150	AF-2	-	-	-
	150	G 2 C - 34 150	200	AF-2	-	-	-
	185	G 2 C - 34 185	200	AF-2	-	-	-
	240	G 2 C - 34 240	250	AF-2	-	-	-
	300	G 2 D - 34 300	300	AF-3	-	-	-







= 1, 2, 8

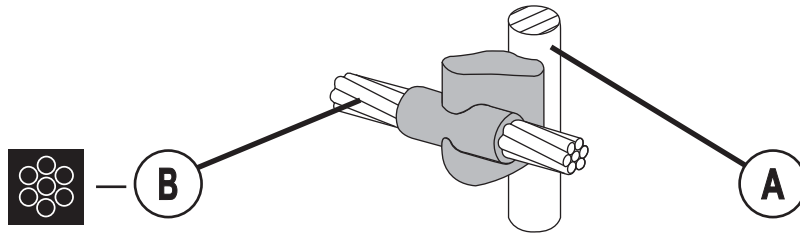





= 5, 15, 16, 17, 18

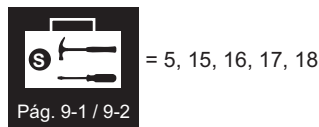
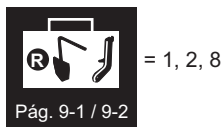

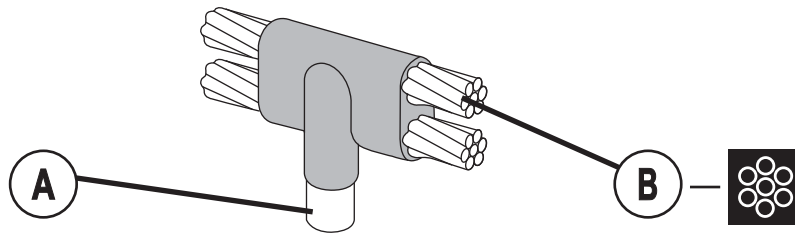
				
1/2" 12,8mm	10	G 3 R - 12 10	90	AF-2
	16	G 3 R - 12 16	90	AF-2
	25	G 3 R - 12 25	90	AF-2
	35	G 3 R - 12 35	90	AF-2
	50	G 3 R - 12 50	115	AF-2
	70	G 3 R - 12 70	115	AF-2
	95	G 3 R - 12 95	150	AF-2
	100	G 3 R - 12 100	150	AF-2
5/8" 14,3mm	120	G 3 R - 12 120	150	AF-2
	16	G 3 R - 58 16	90	AF-2
	25	G 3 R - 58 25	90	AF-2
	35	G 3 R - 58 35	90	AF-2
	50	G 3 R - 58 50	115	AF-2
	70	G 3 R - 58 70	115	AF-2
	95	G 3 R - 58 95	150	AF-2
	100	G 3 R - 58 100	150	AF-2
	120	G 3 R - 58 120	150	AF-2
	150	G 3 R - 58 150	200	AF-2
3/4" 17,3mm	185	G 3 R - 58 185	250	AF-2
	240	G 3 J - 58 240	400	AF-3
	16	G 3 R - 34 16	90	AF-2
	25	G 3 R - 34 25	90	AF-2
	35	G 3 R - 34 35	90	AF-2
	50	G 3 R - 34 50	115	AF-2
	70	G 3 R - 34 70	115	AF-2
	95	G 3 R - 34 95	150	AF-2
	100	G 3 R - 34 100	150	AF-2
	120	G 3 R - 34 120	200	AF-2
	150	G 3 R - 34 150	250	AF-2
	185	G 3 J - 34 185	300	AF-3
240	G 3 J - 34 240	500	AF-3	
300	G 3 J - 34 300	500	AF-3	





A Ø	B mm ²			
1/2" 12,8mm	25	G 4 R - 12 25	115	AF-2
	35	G 4 R - 12 35	115	AF-2
	50	G 4 R - 12 50	150	AF-2
	70	G 4 R - 12 70	200	AF-2
	95	G 4 R - 12 95	250	AF-2
5/8" 14,3mm	25	G 4 R - 58 25	115	AF-2
	35	G 4 R - 58 35	150	AF-2
	50	G 4 R - 58 50	200	AF-2
	70	G 4 R - 58 70	250	AF-2
	95	G 4 F - 58 95	300	AF-3
	100	G 4 F - 58 100	300	AF-3
3/4" 17,3mm	120	G 4 F - 58 120	400	AF-3
	25	G 4 R - 34 25	115	AF-2
	35	G 4 R - 34 35	150	AF-2
	50	G 4 R - 34 50	200	AF-2
	70	G 4 R - 34 70	250	AF-2
	95	G 4 F - 34 95	300	AF-3
	100	G 4 F - 34 100	300	AF-3
120	G 4 F - 34 120	400	AF-3	





= 1, 2, 8

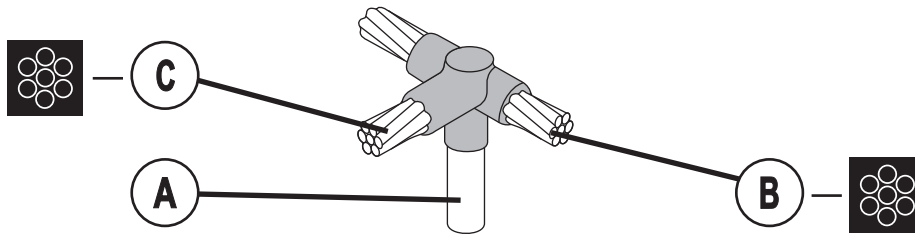

= 5, 15, 16, 17, 18



A Ø	B mm ²	C mm ²		
1/2" 12,8mm	25	25	G 5 M - 12 25 25	90
	35	35	G 5 M - 12 35 35	90
	35	25	G 5 M - 12 35 25	90
	50	50	G 5 M - 12 50 50	115
	50	35	G 5 M - 12 50 35	115
	50	25	G 5 M - 12 50 25	90
	70	70	G 5 M - 12 70 70	115
	70	50	G 5 M - 12 70 50	115
	70	35	G 5 M - 12 70 35	115
	70	25	G 5 M - 12 70 25	115
	95	95	G 5 M - 12 95 95	150
	95	70	G 5 M - 12 95 70	150
	95	50	G 5 M - 12 95 50	115
	95	35	G 5 M - 12 95 35	115
	120	120	G 5 M - 12 120 120	150
	120	95	G 5 M - 12 120 95	150
120	70	G 5 M - 12 120 70	150	
120	50	G 5 M - 12 120 50	150	
5/8" 14,3mm	25	25	G 5 M - 58 25 25	90
	35	35	G 5 M - 58 35 35	115
	35	25	G 5 M - 58 35 25	115
	50	50	G 5 M - 58 50 50	150
	50	35	G 5 M - 58 50 35	150
	50	25	G 5 M - 58 50 25	115
	70	70	G 5 M - 58 70 70	150
	70	50	G 5 M - 58 70 50	150
	70	35	G 5 M - 58 70 35	150
	70	25	G 5 M - 58 70 25	150
	95	95	G 5 M - 58 95 95	200
	95	70	G 5 M - 58 95 70	200
	95	50	G 5 M - 58 95 50	150
	95	35	G 5 M - 58 95 35	150
	120	120	G 5 M - 58 120 120	250
	120	95	G 5 M - 58 120 95	250
120	70	G 5 M - 58 120 70	200	
120	50	G 5 M - 58 120 50	200	
3/4" 17,3mm	25	25	G 5 M - 34 25 25	90
	35	35	G 5 M - 34 35 35	115
	35	25	G 5 M - 34 35 25	115
	50	50	G 5 M - 34 50 50	150
	50	35	G 5 M - 34 50 35	150
	50	25	G 5 M - 34 50 25	150
	70	70	G 5 M - 34 70 70	200
	70	50	G 5 M - 34 70 50	200
	70	35	G 5 M - 34 70 35	150
	70	25	G 5 M - 34 70 25	150
	95	95	G 5 M - 34 95 95	250
	95	70	G 5 M - 34 95 70	250
	95	50	G 5 M - 34 95 50	200
	95	35	G 5 M - 34 95 35	200
	120	120	G 5 M - 34 120 120	250
	120	95	G 5 M - 34 120 95	250
120	70	G 5 M - 34 120 70	200	
120	50	G 5 M - 34 120 50	200	

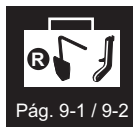

= 1, 8



= 5, 15, 16, 17, 18

G6

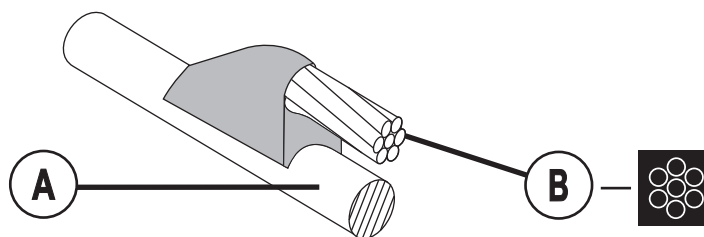

A Ø	B mm ²				MINI 		
1/2" 12,8mm	10	G 6 C - 12 10	25	AF-2	G 6 B - 12 10	25	AF-1
	16	G 6 C - 12 16	45	AF-2	G 6 B - 12 16	32	AF-1
	25	G 6 C - 12 25	45	AF-2	G 6 B - 12 25	45	AF-1
	35	G 6 C - 12 35	45	AF-2	G 6 B - 12 35	45	AF-1
5/8" 14,3mm	16	G 6 C - 58 16	45	AF-2	G 6 B - 58 16	32	AF-1
	25	G 6 C - 58 25	45	AF-2	G 6 B - 58 25	45	AF-1
	35	G 6 C - 58 35	65	AF-2	G 6 B - 58 35	45	AF-1
3/4" 17,3mm	16	G 6 C - 34 16	45	AF-2	G 6 B - 34 16	32	AF-1
	25	G 6 C - 34 25	65	AF-2	G 6 B - 34 25	45	AF-1
	35	G 6 C - 34 35	65	AF-2	G 6 B - 34 35	45	AF-1



GG

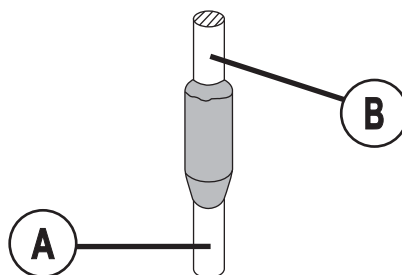

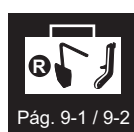

A Ø	B Ø			
1/2" 12,8mm	1/2" 12,8mm	G G R - 12	150	AF-2
5/8" 14,3mm	5/8" 14,3mm	G G R - 58	200	AF-2
3/4" 17,3mm	3/4" 17,3mm	G G R - 34	300	AF-2

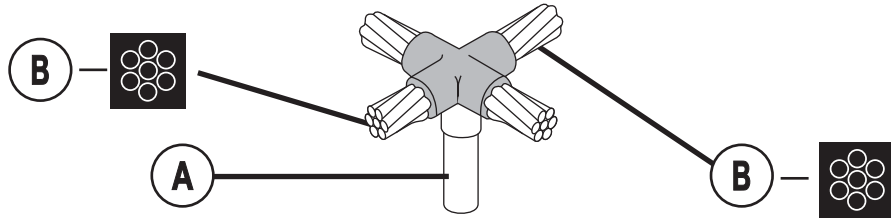

G7



A Ø	B mm ²		
5/8" 14,3mm	25	G 7 M - 58 25	115
	35	G 7 M - 58 35	115
	50	G 7 M - 58 50	150
	70	G 7 M - 58 70	200
	95	G 7 M - 58 95	200
	120	G 7 M - 58 120	250
	150	G 7 M - 58 150	300
	185	G 7 M - 58 185	300
	240	G 7 M - 58 240	2 x 200
3/4" 17,3mm	25	G 7 M - 34 25	115
	35	G 7 M - 34 35	150
	50	G 7 M - 34 50	200
	70	G 7 M - 34 70	200
	95	G 7 M - 34 95	250
	120	G 7 M - 34 120	300
	150	G 7 M - 34 150	2x200
	185	G 7 M - 34 185	2x200
	240	G 7 M - 34 240	2x250







= 1, 8

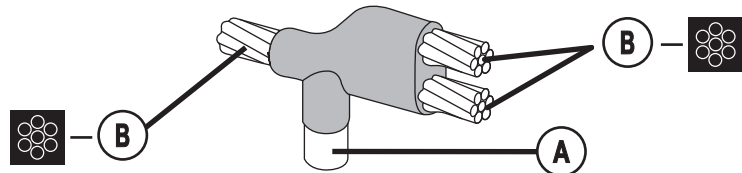

= 5, 15, 16, 17, 18

G8



A Ø	B mm ²			
1/2" 12,8mm	25	G 8 R - 12 25	90	AF-2
	35	G 8 R - 12 35	90	AF-2
	50	G 8 R - 12 50	115	AF-2
	70	G 8 R - 12 70	150	AF-2
	95	G 8 R - 12 95	200	AF-2
5/8" 14,3mm	25	G 8 R - 58 25	90	AF-2
	35	G 8 R - 58 35	115	AF-2
	50	G 8 R - 58 50	150	AF-2
	70	G 8 R - 58 70	200	AF-2
3/4" 17,3mm	95	G 8 R - 58 95	250	AF-2
	25	G 8 R - 34 25	90	AF-2
	35	G 8 R - 34 35	115	AF-2
	50	G 8 R - 34 50	150	AF-2
	70	G 8 R - 34 70	200	AF-2
	95	G 8 R - 34 95	250	AF-2





= 1, 2, 8

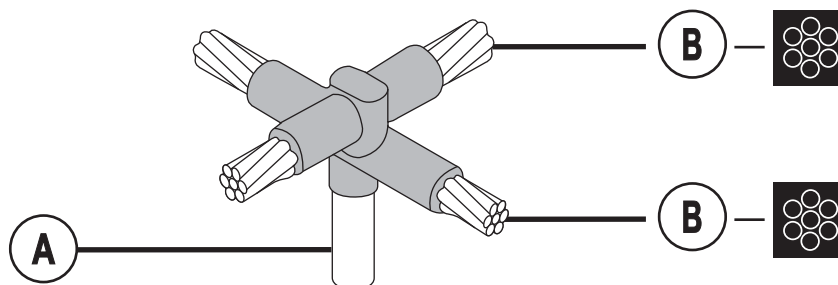

= 5, 15, 16, 17, 18



A Ø	B mm ²		
1/2" 12,8mm	25	G 9 M - 12 25	115
	35	G 9 M - 12 35	115
	50	G 9 M - 12 50	150
	70	G 9 M - 12 70	200
	95	G 9 M - 12 95	250
	120	G 9 M - 12 120	250
5/8" 14,3mm	25	G 9 M - 58 25	115
	35	G 9 M - 58 35	150
	50	G 9 M - 58 50	200
	70	G 9 M - 58 70	250
	95	G 9 M - 58 95	250
	120	G 9 M - 58 120	300
	150	G 9 M - 58 150	2 x 200
	185	G 9 M - 58 185	2 x 200
3/4" 17,3mm	25	G 9 M - 34 25	115
	35	G 9 M - 34 35	150
	50	G 9 M - 34 50	250
	70	G 9 M - 34 70	250
	95	G 9 M - 34 95	300
	120	G 9 M - 34 120	300
	150	G 9 M - 34 150	2 x 250
	185	G 9 M - 34 185	2 x 250
240	G 9 M - 34 240	3 x 250	

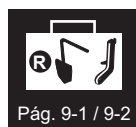

= 1, 8



= 5, 15, 16, 17, 18







Bogotá Sala de Ventas

Carrera 12 No 13 - 46
PBX: 6013360755 - 6013412439
Celular: 312 3055335

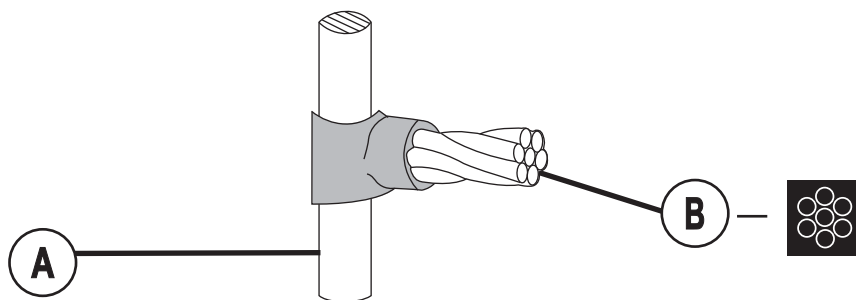
Centro de Distribución

Carrera 18 No 19A - 36
PBX: 6013360755 EXT: 2101



A Ø	B mm ²			
1/2" 12,8mm	10	G 10 R - 12 10	90	AF-2
	16	G 10 R - 12 16	90	AF-2
	25	G 10 R - 12 25	90	AF-2
	35	G 10 R - 12 35	90	AF-2
	50	G 10 R - 12 50	115	AF-2
	70	G 10 R - 12 70	115	AF-2
	95	G 10 R - 12 95	150	AF-2
	100	G 10 R - 12 100	150	AF-2
5/8" 14,3mm	120	G 10 R - 12 120	150	AF-2
	16	G 10 R - 58 16	90	AF-2
	25	G 10 R - 58 25	90	AF-2
	35	G 10 R - 58 35	90	AF-2
	50	G 10 R - 58 50	115	AF-2
	70	G 10 R - 58 70	115	AF-2
	95	G 10 R - 58 95	150	AF-2
	100	G 10 R - 58 100	150	AF-2
	120	G 10 R - 58 120	150	AF-2
	150	G 10 R - 58 150	200	AF-2
185	G 10 R - 58 185	250	AF-2	
240	G 10 D - 58 240	400	AF-3	
3/4" 17,3mm	16	G 10 R - 34 16	90	AF-2
	25	G 10 R - 34 25	90	AF-2
	35	G 10 R - 34 35	90	AF-2
	50	G 10 R - 34 50	115	AF-2
	70	G 10 R - 34 70	150	AF-2
	95	G 10 R - 34 95	150	AF-2
	100	G 10 R - 34 100	150	AF-2
	120	G 10 R - 34 120	200	AF-2
	150	G 10 R - 34 150	250	AF-2
	185	G 10 D - 34 185	300	AF-3
	240	G 10 D - 34 240	500	AF-3
	300	G 10 D - 34 300	500	AF-3



= 1, 2, 8



= 5, 15, 16, 18



Bogotá Sala de Ventas

Carrera 12 No 13 - 46
PBX: 6013360755 - 6013412439
Celular: 312 3055335

Centro de Distribución

Carrera 18 No 19A - 36
PBX: 6013360755 EXT: 2101

SEÇÃO
SECCIÓN
SECTION

3

CONEXÃO FITA OU BARRA DE COBRE A HASTE

CONEXIÓN PLETINA O BARRA DE COBRE A VARILLA

COPPER TAPE OR BAR TO GROUND ROD CONNECTION

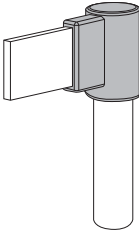
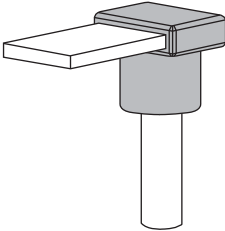
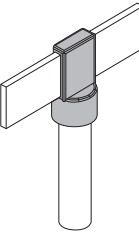
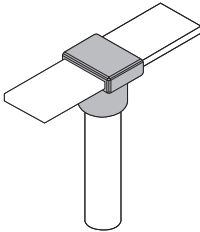
<p>G1 - V</p>  <p>PÁG. 3 - 1</p>	<p>G1 - H</p>  <p>PÁG. 3 - 2</p>
<p>G2 - V</p>  <p>PÁG. 3 - 3</p>	<p>G2 - H</p>  <p>PÁG. 3 - 4</p>







Bogotá Sala de Ventas

Carrera 12 No 13 - 46
PBX: 6013360755 - 6013412439
Celular: 312 3055335

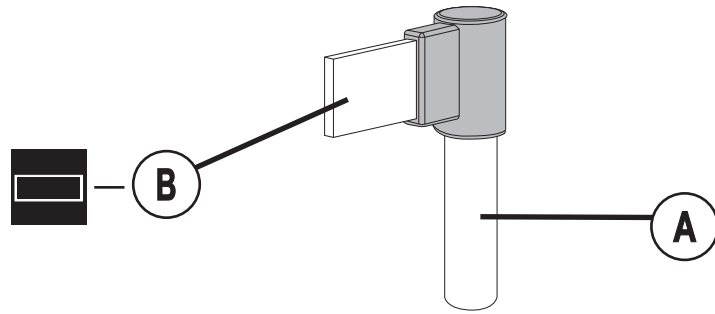
Centro de Distribución

Carrera 18 No 19A - 36
PBX: 6013360755 EXT: 2101



A Ø	B * mm x mm			
1/2" 12,8mm	20 x 1	G 1 C - 12 201 V	65	AF-2
	25 x 1	G 1 C - 12 251 V	65	AF-2
	32 x 1	G 1 C - 12 321 V	90	AF-2
	35 x 1	G 1 C - 12 351 V	90	AF-2
	50 x 1	G 1 C - 12 501 V	115	AF-2
1/2" 12,8mm	17,5 x 2	G 1 C - 12 172 V	90	AF-2
	20 x 2	G 1 C - 12 202 V	90	AF-2
	25 x 2	G 1 C - 12 252 V	90	AF-2
	35 x 2	G 1 C - 12 352 V	115	AF-2
1/2" 12,8mm	20 x 3	G 1 C - 12 203 V	90	AF-2
	25 x 3	G 1 C - 12 253 V	90	AF-2
	35 x 3	G 1 C - 12 353 V	115	AF-2
	50 x 3	G 1 C - 12 503 V	115	AF-2
5/8" 14,3mm	20 x 1	G 1 C - 58 201 V	90	AF-2
	25 x 1	G 1 C - 58 251 V	90	AF-2
	32 x 1	G 1 C - 58 321 V	115	AF-2
	35 x 1	G 1 C - 58 351 V	115	AF-2
	50 x 1	G 1 C - 58 501 V	150	AF-2
5/8" 14,3mm	17,5 x 2	G 1 C - 58 172 V	90	AF-2
	20 x 2	G 1 C - 58 202 V	90	AF-2
	25 x 2	G 1 C - 58 252 V	90	AF-2
	35 x 2	G 1 C - 58 352 V	115	AF-2
5/8" 14,3mm	20 x 3	G 1 C - 58 203 V	90	AF-2
	25 x 3	G 1 C - 58 253 V	115	AF-2
	35 x 3	G 1 C - 58 353 V	115	AF-2
	50 x 3	G 1 C - 58 503 V	150	AF-2
3/4" 17,3mm	20 x 1	G 1 C - 34 201 V	90	AF-2
	25 x 1	G 1 C - 34 251 V	115	AF-2
	32 x 1	G 1 C - 34 321 V	115	AF-2
	35 x 1	G 1 C - 34 351 V	150	AF-2
	50 x 1	G 1 C - 34 501 V	200	AF-2
3/4" 17,3mm	17,5 x 2	G 1 C - 34 172 V	90	AF-2
	20 x 2	G 1 C - 34 202 V	115	AF-2
	25 x 2	G 1 C - 34 252 V	150	AF-2
	35 x 2	G 1 C - 34 352 V	150	AF-2
3/4" 17,3mm	20 x 3	G 1 C - 34 203 V	115	AF-2
	25 x 3	G 1 C - 34 253 V	150	AF-2
	35 x 3	G 1 C - 34 353 V	150	AF-2
	50 x 3	G 1 C - 34 503 V	200	AF-2

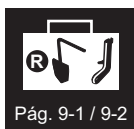

= 1, 2, 8





= 5, 15, 16, 17, 18

B * Nominal - Veja página
Mire la pagina
See page

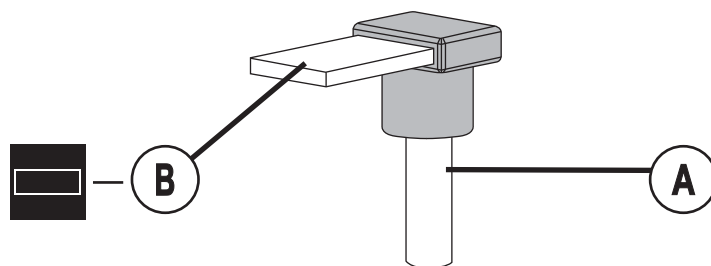
9 - 8



A Ø	B * mm x mm			
1/2" 12,8mm	20 x 1	G 1 C - 12 201 H	45	AF-2
	25 x 1	G 1 C - 12 251 H	45	AF-2
	32 x 1	G 1 C - 12 321 H	45	AF-2
	35 x 1	G 1 C - 12 351 H	65	AF-2
	50 x 1	G 1 C - 12 501 H	65	AF-2
1/2" 12,8mm	17,5 x 2	G 1 C - 12 172 H	65	AF-2
	20 x 2	G 1 C - 12 202 H	65	AF-2
	25 x 2	G 1 C - 12 252 H	65	AF-2
	35 x 2	G 1 C - 12 352 H	65	AF-2
5/8" 14,3mm	20 x 1	G 1 C - 58 201 H	65	AF-2
	25 x 1	G 1 C - 58 251 H	65	AF-2
	32 x 1	G 1 C - 58 321 H	65	AF-2
	35 x 1	G 1 C - 58 351 H	90	AF-2
	50 x 1	G 1 C - 58 501 H	90	AF-2
5/8" 14,3mm	17,5 x 2	G 1 C - 58 172 H	65	AF-2
	20 x 2	G 1 C - 58 202 H	90	AF-2
	25 x 2	G 1 C - 58 252 H	90	AF-2
	35 x 2	G 1 C - 58 352 H	90	AF-2
5/8" 14,3mm	20 x 3	G 1 C - 58 203 H	90	AF-2
	25 x 3	G 1 C - 58 253 H	90	AF-2
	35 x 3	G 1 C - 58 353 H	115	AF-2
	50 x 3	G 1 C - 58 503 H	115	AF-2
3/4" 17,3mm	20 x 1	G 1 C - 34 201 H	90	AF-2
	25 x 1	G 1 C - 34 251 H	90	AF-2
	32 x 1	G 1 C - 34 321 H	90	AF-2
	35 x 1	G 1 C - 34 351 H	90	AF-2
	50 x 1	G 1 C - 34 501 H	115	AF-2
3/4" 17,3mm	17,5 x 2	G 1 C - 34 172 H	90	AF-2
	20 x 2	G 1 C - 34 202 H	90	AF-2
	25 x 2	G 1 C - 34 252 H	90	AF-2
	35 x 2	G 1 C - 34 352 H	115	AF-2
3/4" 17,3mm	20 x 3	G 1 C - 34 203 H	90	AF-2
	25 x 3	G 1 C - 34 253 H	90	AF-2
	35 x 3	G 1 C - 34 353 H	115	AF-2
	50 x 3	G 1 C - 34 503 H	150	AF-2



= 1, 2, 8





= 5, 15, 16, 17, 18

B * Nominal - Veja página
Mire la pagina
See page

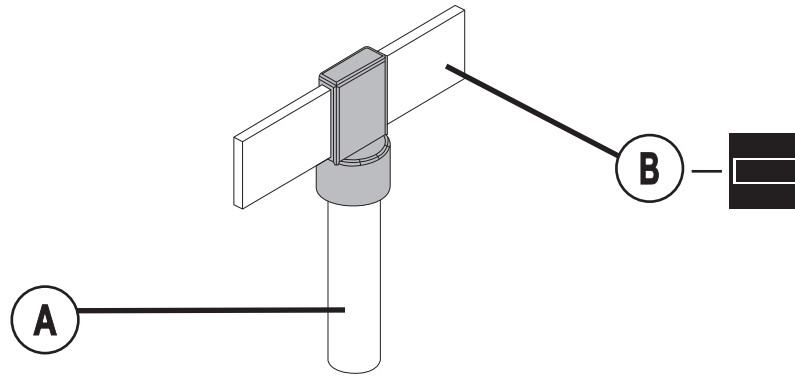
9 - 8



A Ø	B * mm x mm			
1/2" 12,8mm	20 x 1	G 2 C - 12 201 V	45	AF-2
	25 x 1	G 2 C - 12 251 V	65	AF-2
	32 x 1	G 2 C - 12 321 V	65	AF-2
	35 x 1	G 2 C - 12 351 V	65	AF-2
	50 x 1	G 2 C - 12 501 V	90	AF-2
1/2" 12,8mm	17,5 x 2	G 2 C - 12 172 V	65	AF-2
	20 x 2	G 2 C - 12 202 V	65	AF-2
	25 x 2	G 2 C - 12 252 V	90	AF-2
	35 x 2	G 2 C - 12 352 V	90	AF-2
1/2" 12,8mm	20 x 3	G 2 C - 12 203 V	65	AF-2
	25 x 3	G 2 C - 12 253 V	65	AF-2
	35 x 3	G 2 C - 12 353 V	90	AF-2
	50 x 3	G 2 C - 12 503 V	90	AF-2
5/8" 14,3mm	20 x 1	G 2 C - 58 201 V	65	AF-2
	25 x 1	G 2 C - 58 251 V	65	AF-2
	32 x 1	G 2 C - 58 321 V	90	AF-2
	35 x 1	G 2 C - 58 351 V	90	AF-2
	50 x 1	G 2 C - 58 501 V	90	AF-2
5/8" 14,3mm	17,5 x 2	G 2 C - 58 172 V	65	AF-2
	20 x 2	G 2 C - 58 202 V	65	AF-2
	25 x 2	G 2 C - 58 252 V	90	AF-2
	35 x 2	G 2 C - 58 352 V	90	AF-2
5/8" 14,3mm	20 x 3	G 2 C - 58 203 V	90	AF-2
	25 x 3	G 2 C - 58 253 V	90	AF-2
	35 x 3	G 2 C - 58 353 V	90	AF-2
	50 x 3	G 2 C - 58 503 V	115	AF-2
3/4" 17,3mm	20 x 1	G 2 C - 34 201 V	90	AF-2
	25 x 1	G 2 C - 34 251 V	90	AF-2
	32 x 1	G 2 C - 34 321 V	115	AF-2
	35 x 1	G 2 C - 34 351 V	115	AF-2
	50 x 1	G 2 C - 34 501 V	115	AF-2
3/4" 17,3mm	17,5 x 2	G 2 C - 34 172 V	90	AF-2
	20 x 2	G 2 C - 34 202 V	90	AF-2
	25 x 2	G 2 C - 34 252 V	115	AF-2
	35 x 2	G 2 C - 34 352 V	115	AF-2
3/4" 17,3mm	20 x 3	G 2 C - 34 203 V	115	AF-2
	25 x 3	G 2 C - 34 253 V	115	AF-2
	35 x 3	G 2 C - 34 353 V	115	AF-2
	50 x 3	G 2 C - 34 503 V	150	AF-2

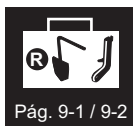

= 1, 2, 8

Pág. 9-1 / 9-2



= 5, 15, 16, 17, 18

Pág. 9-1 / 9-2



B * Nominal - Veja página

Mire la pagina

See page

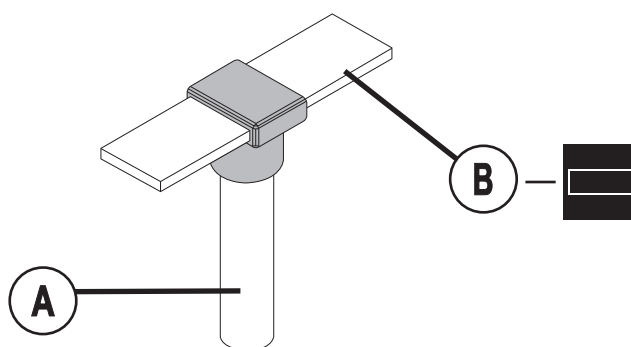
9 - 8



A Ø	B * mm x mm				
1/2" 12,8mm	20 x 1	G 2 C - 12 201 H	45	AF-2	
	25 x 1	G 2 C - 12 251 H	65	AF-2	
	32 x 1	G 2 C - 12 321 H	65	AF-2	
	35 x 1	G 2 C - 12 351 H	65	AF-2	
	50 x 1	G 2 C - 12 501 H	90	AF-2	
1/2" 12,8mm	17,5 x 2	G 2 C - 12 172 H	65	AF-2	
	20 x 2	G 2 C - 12 202 H	65	AF-2	
	25 x 2	G 2 C - 12 252 H	90	AF-2	
	35 x 2	G 2 C - 12 352 H	90	AF-2	
1/2" 12,8mm	20 x 3	G 2 C - 12 203 H	65	AF-2	
	25 x 3	G 2 C - 12 253 H	65	AF-2	
	35 x 3	G 2 C - 12 353 H	90	AF-2	
	50 x 3	G 2 C - 12 503 H	90	AF-2	
5/8" 14,3mm	20 x 1	G 2 C - 58 201 H	65	AF-2	
	25 x 1	G 2 C - 58 251 H	65	AF-2	
	32 x 1	G 2 C - 58 321 H	90	AF-2	
	35 x 1	G 2 C - 58 351 H	90	AF-2	
5/8" 14,3mm	50 x 1	G 2 C - 58 501 H	90	AF-2	
	17,5 x 2	G 2 C - 58 172 H	90	AF-2	
	20 x 2	G 2 C - 58 202 H	90	AF-2	
	25 x 2	G 2 C - 58 252 H	90	AF-2	
5/8" 14,3mm	35 x 2	G 2 C - 58 352 H	90	AF-2	
	20 x 3	G 2 C - 58 203 H	90	AF-2	
	25 x 3	G 2 C - 58 253 H	90	AF-2	
	35 x 3	G 2 C - 58 353 H	90	AF-2	
5/8" 14,3mm	50 x 3	G 2 C - 58 503 H	115	AF-2	
	3/4" 17,3mm	20 x 1	G 2 C - 34 201 H	90	AF-2
		25 x 1	G 2 C - 34 251 H	90	AF-2
		32 x 1	G 2 C - 34 321 H	90	AF-2
35 x 1		G 2 C - 34 351 H	115	AF-2	
50 x 1		G 2 C - 34 501 H	115	AF-2	
3/4" 17,3mm	17,5 x 2	G 2 C - 34 172 H	115	AF-2	
	20 x 2	G 2 C - 34 202 H	115	AF-2	
	25 x 2	G 2 C - 34 252 H	115	AF-2	
	35 x 2	G 2 C - 34 352 H	115	AF-2	
3/4" 17,3mm	20 x 3	G 2 C - 34 203 H	115	AF-2	
	25 x 3	G 2 C - 34 253 H	115	AF-2	
	35 x 3	G 2 C - 34 353 H	115	AF-2	
	50 x 3	G 2 C - 34 503 H	150	AF-2	

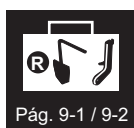

= 1, 2, 8

Pág. 9-1 / 9-2



= 5, 15, 16, 17, 18

Pág. 9-1 / 9-2

B * Nominal - Veja página

Mire la pagina

See page

9 - 8

SEÇÃO
SECCIÓN
SECTION



CONEXÃO BARRA E FITA DE COBRE

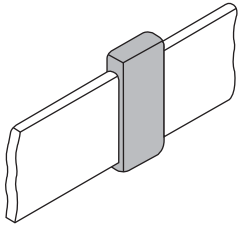
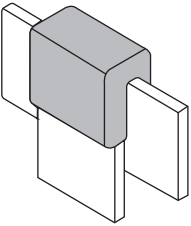
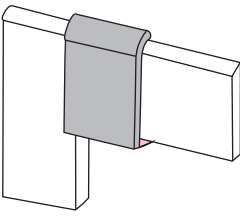
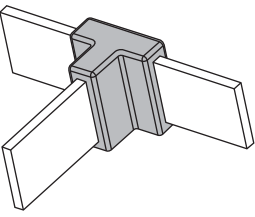
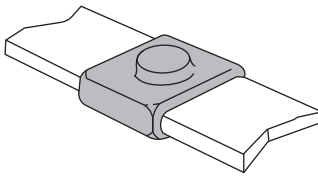
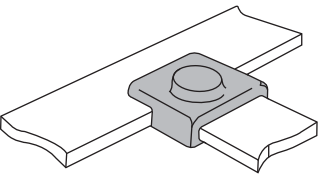
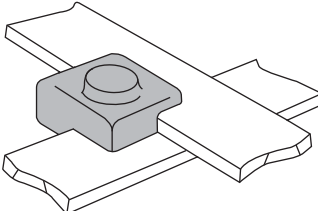
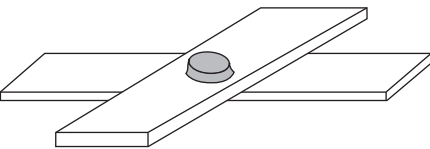
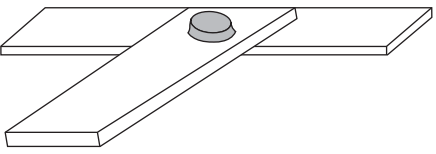
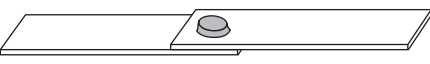

CONEXIÓN PLETINA O BARRA DE COBRE

COPPER TAPE OR COPPER BAR CONNECTION

<p>B1</p>  <p><i>PÁG. 4 - 1</i></p>	<p>B2</p> 
<p>B3</p> 	<p>B4</p> 
<p>B5</p>  <p><i>PÁG. 4 - 2</i></p>	<p>B6</p>  <p><i>PÁG. 4 - 3</i></p>
<p>B7</p> 	<p>B8</p>  <p><i>PÁG. 4 - 4</i></p>
<p>B9</p>  <p><i>PÁG. 4 - 4</i></p>	<p>B0</p>  <p><i>PÁG. 4 - 5</i></p>

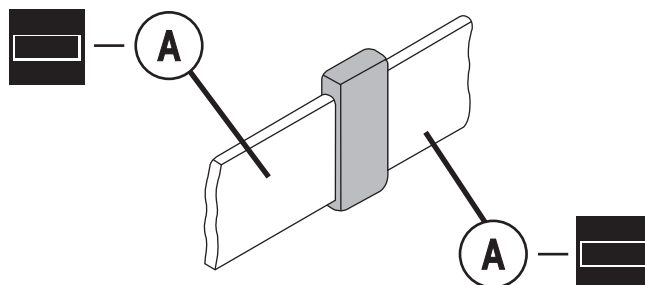
B1



A * mm x mm			
17,5 x 2	B 1 C - 172	45	AF-2
20 x 2	B 1 C - 202	45	AF-2
20 x 3	B 1 C - 203	45	AF-2
25 x 2	B 1 C - 252	65	AF-2
25 x 3	B 1 C - 253	65	AF-2
25 x 4	B 1 C - 254	65	AF-2
25 x 6	B 1 C - 256	65	AF-2
30 x 2	B 1 C - 302	65	AF-2
30 x 3	B 1 C - 303	65	AF-2
30 x 4	B 1 C - 304	65	AF-2
30 x 6	B 1 C - 306	90	AF-2
38 x 3	B 1 C - 383	90	AF-2
38 x 4	B 1 C - 384	90	AF-2
38 x 6	B 1 C - 386	90	AF-2
40 x 3	B 1 C - 403	115	AF-2
40 x 4	B 1 C - 404	115	AF-2
40 x 6	B 1 C - 406	115	AF-2
50 x 3	B 1 C - 503	150	AF-2
50 x 4	B 1 C - 504	200	AF-2
50 x 6	B 1 C - 506	200	AF-2
50 x 8	B 1 D - 508	300	AF-3
60 x 6	B 1 C - 606	300	AF-2
60 x 8	B 1 D - 608	300	AF-3



= 1, 2





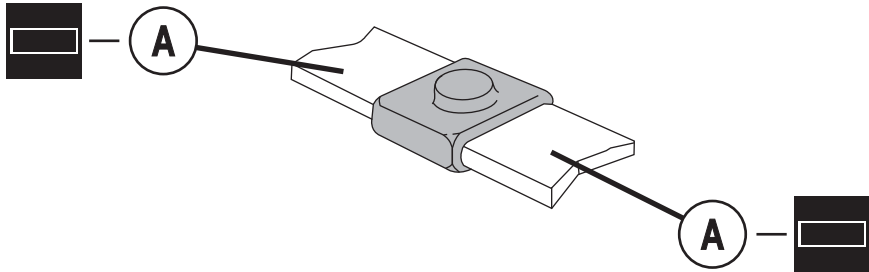

= 5, 15, 16, 17, 18

A * Nominal - Veja página
Mire la pagina
See page

9 - 8



 *			
mm x mm			
17,5 x 2	B 5 C - 172	45	AF-2
20 x 2	B 5 C - 202	45	AF-2
20 x 3	B 5 C - 203	45	AF-2
20 x 4	B 5 C - 204	65	AF-2
25 x 2	B 5 C - 252	45	AF-2
25 x 3	B 5 C - 253	65	AF-2
25 x 4	B 5 C - 254	90	AF-2
25 x 6	B 5 C - 256	115	AF-2
30 x 2	B 5 C - 302	65	AF-2
30 x 3	B 5 C - 303	65	AF-2
30 x 4	B 5 C - 304	90	AF-2
30 x 6	B 5 C - 306	150	AF-2
38 x 3	B 5 C - 383	90	AF-2
38 x 4	B 5 C - 384	150	AF-2
38 x 6	B 5 C - 386	200	AF-2
40 x 3	B 5 C - 403	90	AF-2
40 x 4	B 5 C - 404	115	AF-2
40 x 6	B 5 C - 406	200	AF-2
50 x 3	B 5 C - 503	150	AF-2
50 x 4	B 5 C - 504	200	AF-2
50 x 6	B 5 C - 506	250	AF-2
50 x 8	B 5 D - 508	300	AF-3
60 x 6	B 5 D - 606	300	AF-3
60 x 8	B 5 D - 608	400	AF-3



= 1, 2







= 5, 15, 16, 17, 18

A * Nominal - Veja página
Mire la pagina
See page

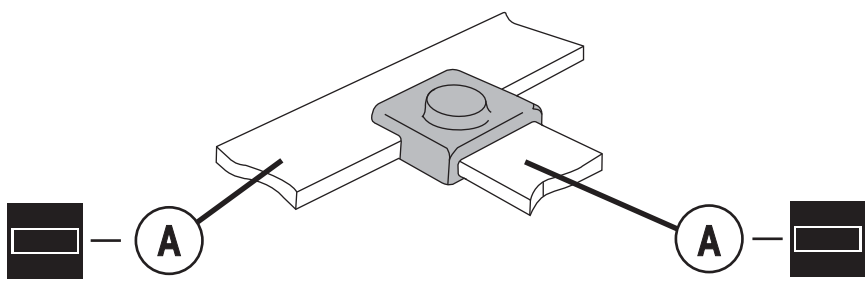
9 - 8

B6



 *			
mm x mm			
17,5 x 2	B 6 C - 172	45	AF-2
20 x 2	B 6 C - 202	45	AF-2
20 x 3	B 6 C - 203	45	AF-2
20 x 4	B 6 C - 204	65	AF-2
25 x 2	B 6 C - 252	45	AF-2
25 x 3	B 6 C - 253	65	AF-2
25 x 4	B 6 C - 254	90	AF-2
25 x 6	B 6 C - 256	115	AF-2
30 x 2	B 6 C - 302	65	AF-2
30 x 3	B 6 C - 303	65	AF-2
30 x 4	B 6 C - 304	90	AF-2
30 x 6	B 6 C - 306	150	AF-2
38 x 3	B 6 C - 383	90	AF-2
38 x 4	B 6 C - 384	150	AF-2
38 x 6	B 6 C - 386	200	AF-2
40 x 3	B 6 C - 403	90	AF-2
40 x 4	B 6 C - 404	115	AF-2
40 x 6	B 6 C - 406	200	AF-2
50 x 3	B 6 C - 503	150	AF-2
50 x 4	B 6 C - 504	200	AF-2
50 x 6	B 6 C - 506	250	AF-2
50 x 8	B 6 D - 508	300	AF-3
60 x 6	B 6 D - 606	300	AF-3
60 x 8	B 6 D - 608	400	AF-3

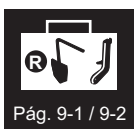

= 1, 2







= 5, 15, 16, 17, 18

A * Nominal - Veja página
Mire la pagina
See page

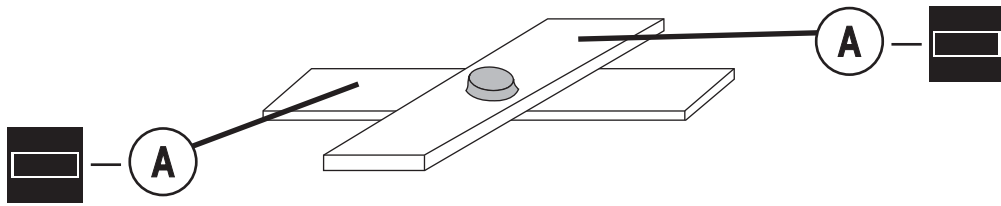
9 - 8

B8



A *			
mm x mm			
25 x 0,5	B 8 C - 2505	25	AF-2
50 x 0,5	B 8 C - 5005	25	AF-2
20 x 1	B 8 C - 201	45	AF-2
25 x 1	B 8 C - 251	45	AF-2
32 x 1	B 8 C - 321	45	AF-2
35 x 1	B 8 C - 351	45	AF-2
40 x 1	B 8 C - 401	45	AF-2
50 x 1	B 8 C - 501	45	AF-2

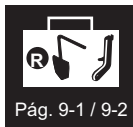

= 1, 2







= 5, 15, 16, 17, 18

A * Nominal - Veja página
Mire la pagina
See page

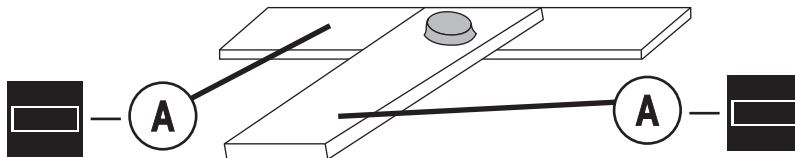
9 - 8

B9



A *			
mm x mm			
25 x 0,5	B 9 C - 2505	25	AF-2
50 x 0,5	B 9 C - 5005	25	AF-2
20 x 1	B 9 C - 201	45	AF-2
25 x 1	B 9 C - 251	45	AF-2
32 x 1	B 9 C - 321	45	AF-2
35 x 1	B 9 C - 351	45	AF-2
40 x 1	B 9 C - 401	45	AF-2
50 x 1	B 9 C - 501	45	AF-2

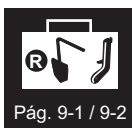

= 1, 2





= 5, 15, 16, 17, 18

A * Nominal - Veja página
Mire la pagina
See page

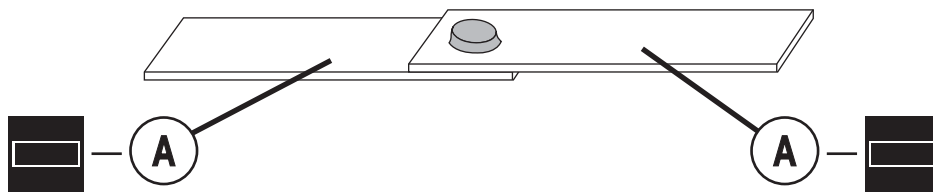
9 - 8



A * mm x mm			
25 x 0,5	B 0 C - 2505	25	AF-2
50 x 0,5	B 0 C - 5005	25	AF-2
20 x 1	B 0 C - 201	45	AF-2
25 x 1	B 0 C - 251	45	AF-2
32 x 1	B 0 C - 321	45	AF-2
35 x 1	B 0 C - 351	45	AF-2
40 x 1	B 0 C - 401	45	AF-2
50 x 1	B 0 C - 501	45	AF-2



= 1, 2



= 5, 15, 16, 17, 18

A * Nominal - Veja página
Mire la pagina
See page

9 - 8

SEÇÃO
SECCIÓN
SECTION

5

CONEXÃO CABO A SUPERFÍCIE METÁLICA VERTICAL
CONEXIÓN CABLE A SUPERFICIE METÁLICA VERTICAL
COPPER CABLE TO VERTICAL STEEL SURFACE CONNECTION

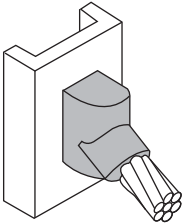
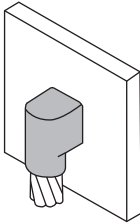
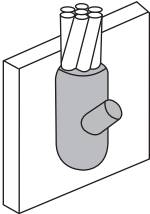
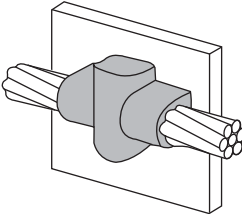
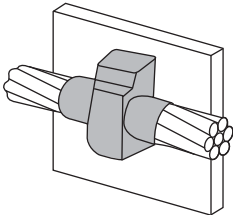
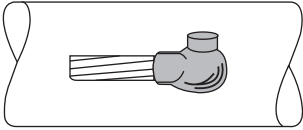
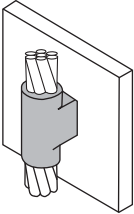
<p>V1</p>  <p>PÁG. 5 - 1</p>	<p>V3</p>  <p>PÁG. 5 - 1</p>
<p>V4</p>  <p>PÁG. 5 - 2</p>	<p>V5</p>  <p>PÁG. 5 - 2</p>
<p>V6</p>  <p>PÁG. 5 - 3</p>	<p>V7</p>  <p>PÁG. 5 - 3</p>
<p>V8</p>  <p>PÁG. 5 - 4</p>	



Bogotá Sala de Ventas

Carrera 12 No 13 - 46
PBX: 6013360755 - 6013412439
Celular: 312 3055335

Centro de Distribución

Carrera 18 No 19A - 36
PBX: 6013360755 EXT: 2101

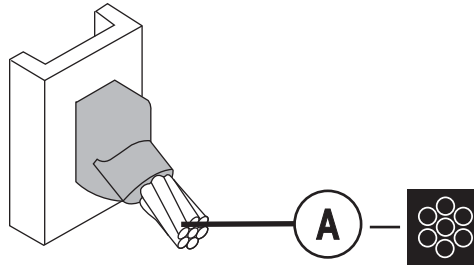

A mm ²				MINI 		
10	V 1 C - 10	45	AF-2	V 1 B - 10	45	AF-1
16	V 1 C - 16	45	AF-2	V 1 B - 16	45	AF-1
25	V 1 C - 25	45	AF-2	V 1 B - 25	45	AF-1
35	V 1 C - 35	45	AF-2	V 1 B - 35	45	AF-1
50	V 1 C - 50	90	AF-2	-	-	-
70	V 1 C - 70	90	AF-2	-	-	-
95	V 1 C - 95	115	AF-2	-	-	-
100	V 1 C - 100	115	AF-2	-	-	-
120	V 1 C - 120	115	AF-2	-	-	-
150	V 1 C - 150	115	AF-2	-	-	-
185	V 1 C - 185	200	AF-2	-	-	-
240	V 1 C - 240	200	AF-2	-	-	-
300	V 1 C - 300	250	AF-2	-	-	-

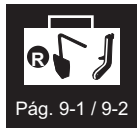

= 1, 2, 6



= 5, 10, 15, 16, 17, 18

- Possibilidade de furo na parede metálica. Recomendamos fazer uma solda teste.
- Hay posibilidad de dañar la superficie metálica. Recomendamos ejecutar una soldadura teste.
- There is a possibility of perforation on the metallic surface, we recommend to do a test weld .

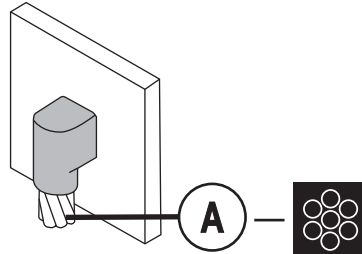

A mm ²			
10	V 3 C - 10	45	AF-2
16	V 3 C - 16	65	AF-2
25	V 3 C - 25	65	AF-2
35	V 3 C - 35	65	AF-2
50	V 3 C - 50	115	AF-2
70	V 3 C - 70	115	AF-2
95	V 3 C - 95	150	AF-2
100	V 3 C - 100	150	AF-2
120	V 3 C - 120	200	AF-2
150	V 3 C - 150	200	AF-2
185	V 3 C - 185	250	AF-2
240	V 3 R - 240	300	AF-2
300	V 3 R - 300	300	AF-2



= 1, 2, 6





= 5, 10, 15, 16, 17, 18

- Possibilidade de furo na parede metálica. Recomendamos fazer uma solda teste.
- Hay posibilidad de dañar la superficie metálica. Recomendamos ejecutar una soldadura teste.
- There is a possibility of perforation on the metallic surface, we recommend to do a test weld .

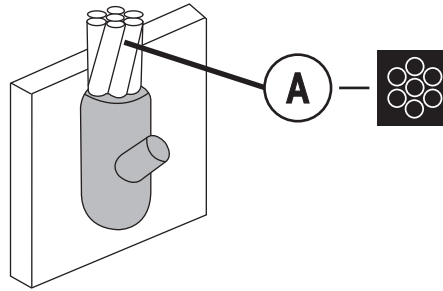
V4



A mm ²			
10	V 4 C - 10	65	AF-2
16	V 4 C - 16	65	AF-2
25	V 4 C - 25	65	AF-2
35	V 4 C - 35	65	AF-2
50	V 4 C - 50	115	AF-2
70	V 4 C - 70	150	AF-2
95	V 4 R - 95	200	AF-2
100	V 4 R - 100	200	AF-2
120	V 4 R - 120	200	AF-2
150	V 4 R - 150	250	AF-2
185	V 4 F - 185	300	AF-3
240	V 4 F - 240	300	AF-3
300	V 4 F - 300	400	AF-3



= 1, 2, 6







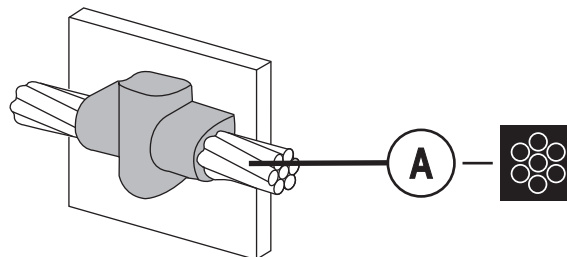

= 5, 10, 15, 16, 17, 18

- Possibilidade de furo na parede metálica. Recomendamos fazer uma solda teste.
- Hay posibilidad de dañar la superficie metálica. Recomendamos ejecutar una soldadura teste.
- There is a possibility of perforation on the metallic surface, we recommend to do a test weld .

V5



A mm ²				MINI 		
10	V 5 C - 10	45	AF-2	V 5 B - 10	45	AF-1
16	V 5 C - 16	45	AF-2	V 5 B - 16	45	AF-1
25	V 5 C - 25	45	AF-2	V 5 B - 25	45	AF-1
35	V 5 C - 35	45	AF-2	V 5 B - 35	45	AF-1
50	V 5 C - 50	115	AF-2	-	-	-
70	V 5 C - 70	115	AF-2	-	-	-
95	V 5 C - 95	150	AF-2	-	-	-
100	V 5 C - 100	150	AF-2	-	-	-
120	V 5 C - 120	150	AF-2	-	-	-
150	V 5 D - 150	200	AF-3	-	-	-
185	V 5 D - 185	250	AF-3	-	-	-
240	V 5 D - 240	300	AF-3	-	-	-
300	V 5 D - 300	400	AF-3	-	-	-



= 1, 2, 6



= 5, 10, 15, 16, 17, 18

- Possibilidade de furo na parede metálica. Recomendamos fazer uma solda teste.
- Hay posibilidad de dañar la superficie metálica. Recomendamos ejecutar una soldadura teste.
- There is a possibility of perforation on the metallic surface, we recommend to do a test weld .

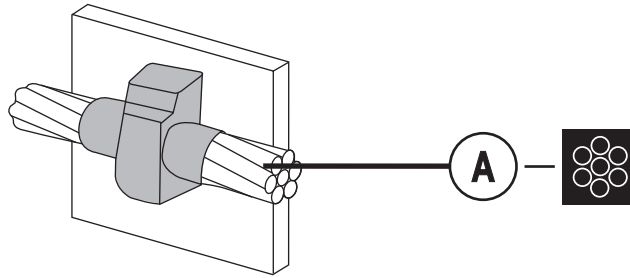

A mm ²				MINI 		
10	V 6 C - 10	45	AF-2	V 6 B - 10	45	AF-1
16	V 6 C - 16	65	AF-2	V 6 B - 16	65	AF-1
25	V 6 C - 25	65	AF-2	V 6 B - 25	65	AF-1
35	V 6 C - 35	65	AF-2	V 6 B - 35	65	AF-1
50	V 6 C - 50	115	AF-2	-	-	-
70	V 6 C - 70	115	AF-2	-	-	-
95	V 6 C - 95	150	AF-2	-	-	-
100	V 6 C - 100	150	AF-2	-	-	-
120	V 6 C - 120	150	AF-2	-	-	-
150	V 6 D - 150	200	AF-3	-	-	-
185	V 6 D - 185	250	AF-3	-	-	-
240	V 6 D - 240	300	AF-3	-	-	-
300	V 6 D - 300	400	AF-3	-	-	-



- Possibilidade de furo na parede metálica. Recomendamos fazer uma solda teste.
- Hay posibilidad de dañar la superficie metálica. Recomendamos ejecutar una soldadura teste.
- There is a possibility of perforation on the metallic surface, we recommend to do a test weld .

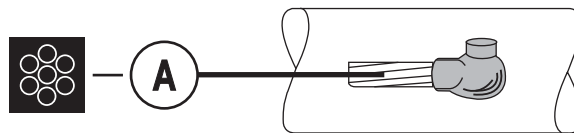





A mm ²			
10	V 7 C - 10	45.L2	AF-2
16	V 7 C - 16	45	AF-2
25	V 7 C - 25	45	AF-2
35	V 7 C - 35	45	AF-2
50	V 7 C - 50	90	AF-2
70	V 7 C - 70	90	AF-2
95	V 7 C - 95	90	AF-2
100	V 7 C - 100	90	AF-2
120	V 7 C - 120	115	AF-2
150	V 7 C - 150	150	AF-2
185	V 7 C - 185	200	AF-2
240	V 7 C - 240	300	AF-2

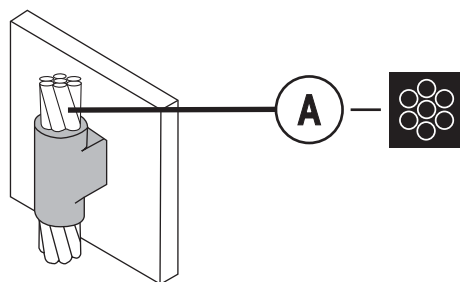

- Possibilidade de furo na parede metálica. Recomendamos fazer uma solda teste.
- Hay posibilidad de dañar la superficie metálica. Recomendamos ejecutar una soldadura teste.
- There is a possibility of perforation on the metallic surface, we recommend to do a test weld .



 mm ²			
10	V 8 C - 10	65	AF-2
16	V 8 C - 16	90	AF-2
25	V 8 C - 25	90	AF-2
35	V 8 C - 35	115	AF-2
50	V 8 R - 50	200	AF-2
70	V 8 R - 70	200	AF-2
95	V 8 R - 95	250	AF-2
100	V 8 F - 100	250	AF-2
120	V 8 R - 120	250	AF-2
150	V 8 F - 150	200	AF-3
185	V 8 F - 185	250	AF-3
240	V 8 F - 240	300	AF-3

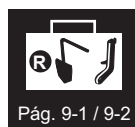

= 1, 2, 6



= 5, 10, 15, 16, 17, 18

- Possibilidade de furo na parede metálica. Recomendamos fazer uma solda teste.
- Hay posibilidad de dañar la superficie metálica. Recomendamos ejecutar una soldadura teste.
- There is a possibility of perforation on the metallic surface, we recommend to do a test weld .

SEÇÃO
SECCIÓN
SECTION

6

CONEXÃO CABO A SUPERFÍCIE METÁLICA HORIZONTAL
CONEXIÓN CABLE A SUPERFICIE METÁLICA HORIZONTAL
COPPER CABLE TO HORIZONTAL STEEL SURFACE CONNECTION

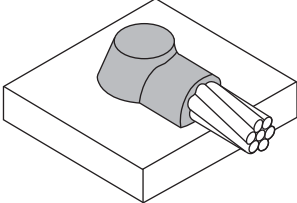
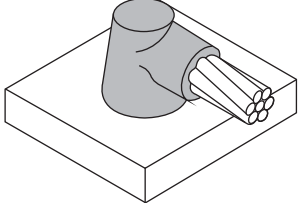
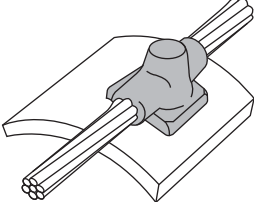
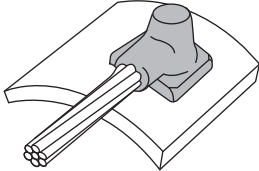
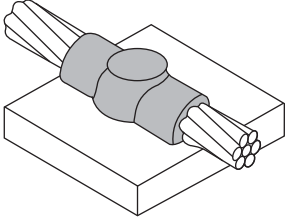
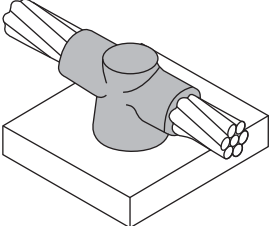
<p>H1</p>  <p>PÁG. 6 - 1</p>	<p>H2</p>  <p>PÁG. 6 - 1</p>
<p>H3</p>  <p>PÁG. 6 - 2</p>	<p>H4</p>  <p>PÁG. 6 - 3</p>
<p>H5</p>  <p>PÁG. 6 - 4</p>	<p>H6</p>  <p>PÁG. 6 - 4</p>



Bogotá Sala de Ventas



Carrera 12 No 13 - 46
PBX: 6013360755 - 6013412439
Celular: 312 3055335

Centro de Distribución

Carrera 18 No 19A - 36
PBX: 6013360755 EXT: 2101

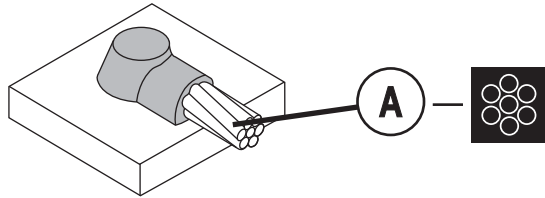
H1



A mm ²			
10	H 1 A - 10	45.L2	-
16	H 1 A - 16	45	-
25	H 1 A - 25	45	-
35	H 1 A - 35	45	-



= 1





= 5, 10, 12, 15, 16, 17, 18

- Possibilidade de furo na parede metálica. Recomendamos fazer uma solda teste.
- Hay posibilidad de dañar la superficie metálica. Recomendamos ejecutar una soldadura teste.
- There is a possibility of perforation on the metallic surface, we recommend to do a test weld .

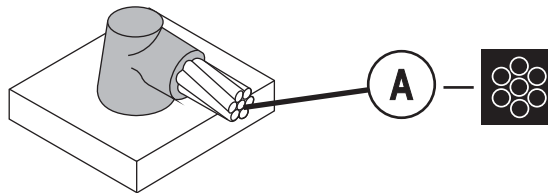
H2



A mm ²			
10	USE H1		
16			
25			
35			
50	H 2 C - 50	90	AF-2
70	H 2 C - 70	90	AF-2
95	H 2 C - 95	115	AF-2
100	H 2 C - 100	115	AF-2
120	H 2 C - 120	115	AF-2
150	H 2 C - 150	150	AF-2
185	H 2 C - 185	200	AF-2
240	H 2 C - 240	200	AF-2
300	H 2 D - 300	300	AF-3



= 1, 2





= 5, 10, 15, 16, 17, 18

- Possibilidade de furo na parede metálica. Recomendamos fazer uma solda teste.
- Hay posibilidad de dañar la superficie metálica. Recomendamos ejecutar una soldadura teste.
- There is a possibility of perforation on the metallic surface, we recommend to do a test weld .

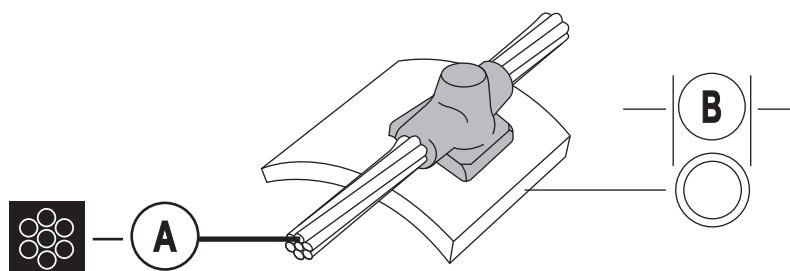
H3



A mm ²	B mm Ø			
10	< 125	H 3 A - 10-A	32	-
10	> 125	H 3 A - 10-B	32	-
16	< 125	H 3 A - 16-A	45	-
16	> 125	H 3 A - 16-B	45	-
25	< 70	H 3 A - 25-C	45	-
25	70 - 165	H 3 A - 25-D	45	-
25	> 165	H 3 A - 25-E	45	-
35	< 70	H 3 A - 35-C	45	-
35	70 - 165	H 3 A - 35-D	45	-
35	165 - 250	H 3 A - 35-F	45	-
35	> 250	H 3 A - 35-G	45	-
50	< 70	H 3 C - 50-C	65	AF-2
50	70 - 165	H 3 C - 50-D	65	AF-2
50	165 - 250	H 3 C - 50-F	65	AF-2
50	> 250	H 3 C - 50-G	65	AF-2

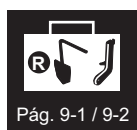





= 1, 2,

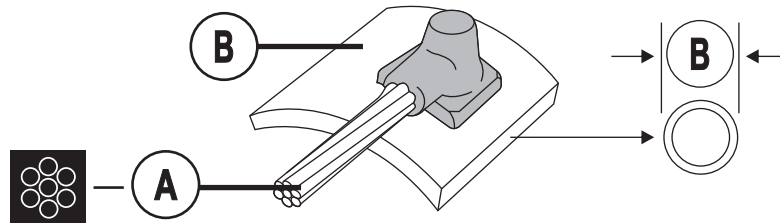

= 5, 10, 12, 15, 16, 17, 18

- Possibilidade de furo na parede metálica. Recomendamos fazer uma solda teste.
- Hay posibilidad de dañar la superficie metálica. Recomendamos ejecutar una soldadura teste.
- There is a possibility of perforation on the metallic surface, we recommend to do a test weld .



A mm ²	B mm Ø			
10	< 125	H 4 A - 10-A	25	-
10	> 125	H 4 A - 10-B	25	-
16	< 125	H 4 A - 16-A	25	-
16	> 125	H 4 A - 16-B	25	-
25	< 70	H 4 A - 25-C	25	-
25	70 - 165	H 4 A - 25-D	25	-
25	> 165	H 4 A - 25-E	25	-
35	< 70	H 4 A - 35-C	32	-
35	70 - 165	H 4 A - 35-D	32	-
35	165 - 250	H 4 A - 35-F	32	-
35	> 250	H 4 A - 35-G	32	-
50	< 70	H 4 A - 50-C	45	-
50	70 - 165	H 4 A - 50-D	45	-
50	165 - 250	H 4 A - 50-F	45	-
50	> 250	H 4 A - 50-G	45	-
70	< 70	H 4 A - 70-C	65	-
70	70 - 165	H 4 A - 70-D	65	-
70	165 - 250	H 4 A - 70-F	65	-
70	> 250	H 4 A - 70-G	65	-



= 1





= 5, 10, 12, 15, 16, 17, 18

- Possibilidade de furo na parede metálica. Recomendamos fazer uma solda teste.
- Hay posibilidad de dañar la superficie metálica. Recomendamos ejecutar una soldadura teste.
- There is a possibility of perforation on the metallic surface, we recommend to do a test weld .

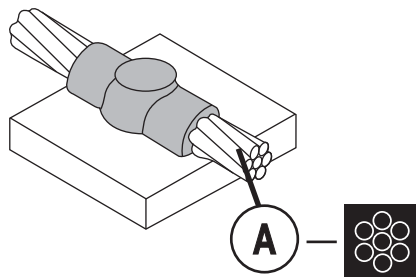
H5





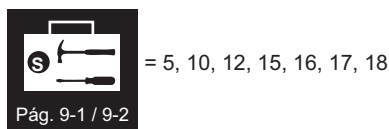
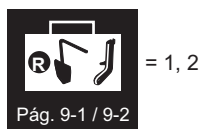

A mm ²			
10	H 5 A-10	45	-
16	H 5 A-16	45	-
25	H 5 A-25	45	-
35	H 5 A-35	45	-
50	H 5 C - 50	90	AF-2
70	H 5 C - 70	115	AF-2
95	H 5 C - 95	115	AF-2
100	H 5 C - 100	115	AF-2
120	H 5 C - 120	150	AF-2
150	H 5 C - 150	200	AF-2
185	H 5 C - 185	250	AF-2
240	H 5 C - 240	300	AF-2

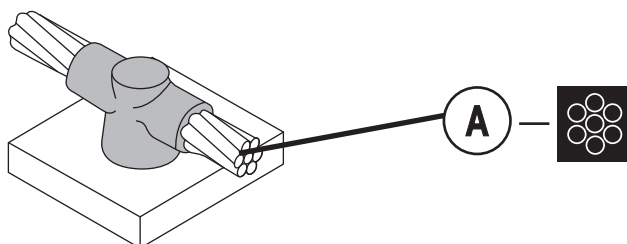

- Possibilidade de furo na parede metálica. Recomendamos fazer uma solda teste.
- Hay posibilidad de dañar la superficie metálica. Recomendamos ejecutar una soldadura teste.
- There is a possibility of perforation on the metallic surface, we recommend to do a test weld .

H6



A mm ²			
10	USE H5		
16			
25			
35			
50	H 6 C - 50	90	AF-2
70	H 6 C - 70	115	AF-2
95	H 6 C - 95	115	AF-2
100	H 6 C - 100	115	AF-2
120	H 6 C - 120	150	AF-2
150	H 6 C - 150	200	AF-2
185	H 6 C - 185	250	AF-2
240	H 6 D - 240	300	AF-3
300	H 6 D - 300	400	AF-3

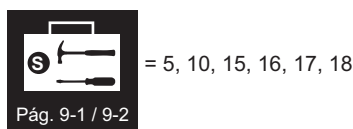

- Possibilidade de furo na parede metálica. Recomendamos fazer uma solda teste.
- Hay posibilidad de dañar la superficie metálica. Recomendamos ejecutar una soldadura teste.
- There is a possibility of perforation on the metallic surface, we recommend to do a test weld .

SEÇÃO
SECCIÓN
SECTION



CONEXÃO CABO A BARRA DE COBRE

CONEXIÓN CABLE A BARRA DE COBRE

COPPER CABLE TO COPPER BAR CONNECTION

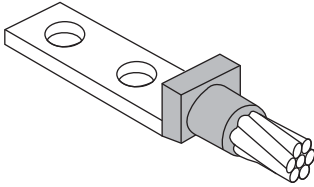
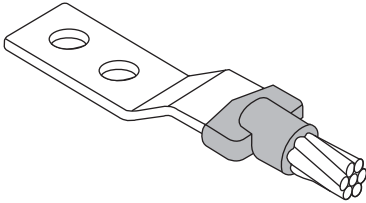
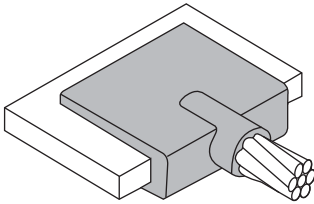
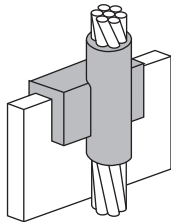
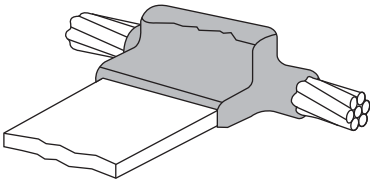
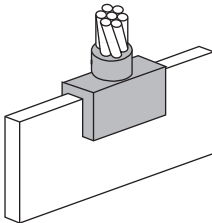
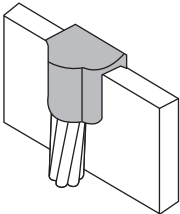
<p>L1</p>  <p>PÁG. 7 - 1</p>	<p>L2</p>  <p>PÁG. 7 - 1</p>
<p>L3</p>  <p>PÁG. 7 - 2</p>	<p>L4</p> 
<p>L5</p>  <p>PÁG. 7 - 3</p>	<p>L6</p> 
<p>L7</p> 	

L1

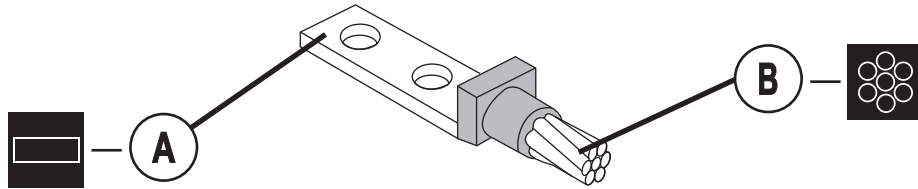

(A)	(B) mm ²						
1/8 x 1" 3 x 25	25	L 1 C - TA 25	32	AF-2	L 1 B - TA 25	32	AF-1
	35	L 1 C - TA 35	32	AF-2	L 1 B - TA 35	32	AF-1
	50	L 1 C - TA 50	45	AF-2	L 1 B - TA 50	45	AF-1
	70	L 1 C - TA 70	45	AF-2	L 1 B - TA 70	45	AF-1
	95	L 1 C - TA 95	65	AF-2	L 1 B - TA 95	65	AF-1
3/16 x 1" 4 x 25	25	L 1 C - CB 25	45	AF-2	L 1 B - CB 25	45	AF-1
	35	L 1 C - CB 35	65	AF-2	L 1 B - CB 35	65	AF-1
	50	L 1 C - CB 50	65	AF-2	L 1 B - CB 50	65	AF-1
	70	L 1 C - CB 70	65	AF-2	L 1 B - CB 70	65	AF-1
	95	L 1 C - CB 95	90	AF-2	-	-	-
1/4 x 1" 6 x 25	50	L 1 C - SA 50	65	AF-2	L 1 B - CB 50	65	AF-1
	70	L 1 C - SA 70	90	AF-2	-	-	-
	95	L 1 C - SA 95	90	AF-2	-	-	-



L2

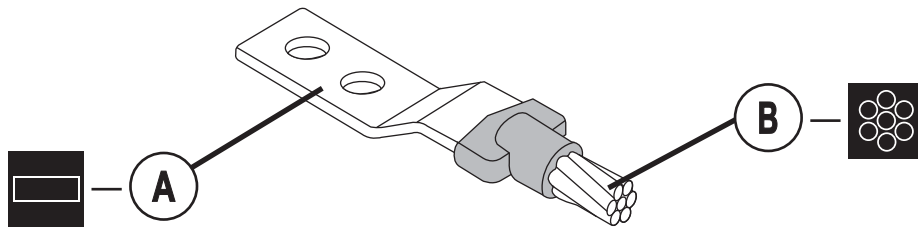

(A)	(B) mm ²						
1/8 x 1" 3 x 25	25	L 2 C - TA 25	45	AF-2	L 2 B - TA 25	45	AF-1
	35	L 2 C - TA 35	45	AF-2	L 2 B - TA 35	45	AF-1
	50	L 2 C - TA 50	45	AF-2	L 2 B - TA 50	45	AF-1
	70	L 2 C - TA 70	65	AF-2	L 2 B - TA 70	65	AF-1
	95	L 2 C - TA 95	65	AF-2	L 2 B - TA 95	65	AF-1
3/16 x 1" 4 x 25	25	L 2 C - CB 25	45	AF-2	L 2 B - CB 25	45	AF-1
	35	L 2 C - CB 35	65	AF-2	L 2 B - CB 35	65	AF-1
	50	L 2 C - CB 50	65	AF-2	L 2 B - CB 50	65	AF-1
	70	L 2 C - CB 70	65	AF-2	L 2 B - CB 70	65	AF-1
	95	L 2 C - CB 95	90	AF-2	-	-	-
1/4 x 1" 6 x 25	25	L 2 C - SA 25	65	AF-2	L 2 B - SA 25	65	AF-1
	35	L 2 C - SA 35	65	AF-2	L 2 B - SA 35	65	AF-1
	50	L 2 C - SA 50	65	AF-2	L 2 B - SA 50	65	AF-1
	70	L 2 C - SA 70	65	AF-2	L 2 B - SA 70	65	AF-1
	95	L 2 C - SA 95	90	AF-2	-	-	-



L3

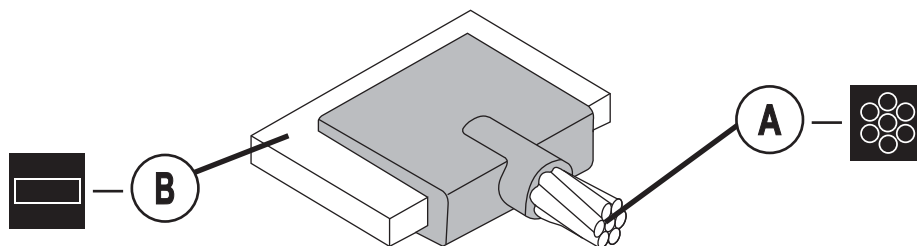

A mm ²	B mm x mm				MINI 		
10	20 x 2	L 3 C - 10202	25	AF-2	L 3 B - 10202	25	AF-1
16	20 x 2	L 3 C - 16202	32	AF-2	L 3 B - 16202	32	AF-1
16	20 x 3	L 3 C - 16203	45	AF-2	L 3 B - 16203	45	AF-1
16	25 x 3	L 3 C - 16253	45	AF-2	L 3 B - 16253	45	AF-1
25	20 x 2	L 3 C - 25202	25	AF-2	L 3 B - 25202	25	AF-1
25	20 x 3	L 3 C - 25203	32	AF-2	L 3 B - 25203	32	AF-1
25	25 x 3	L 3 C - 25253	32	AF-2	L 3 B - 25253	32	AF-1
35	20 x 2	L 3 C - 35202	32	AF-2	L 3 B - 35202	32	AF-1
35	20 x 3	L 3 C - 35203	45	AF-2	L 3 B - 35203	45	AF-1
35	25 x 3	L 3 C - 35253	45	AF-2	L 3 B - 35253	45	AF-1
50	20 x 3	L 3 C - 50203	45	AF-2	L 3 B - 50203	45	AF-1
50	25 x 2	L 3 C - 50252	45	AF-2	L 3 B - 50252	45	AF-1
50	25 x 3	L 3 C - 50253	45	AF-2	L 3 B - 50253	45	AF-1
70	25 x 3	L 3 C - 70253	65	AF-2	L 3 B - 70253	65	AF-1
70	25 x 4	L 3 C - 70254	65	AF-2	L 3 B - 70254	65	AF-1
70	25 x 6	L 3 C - 70256	90	AF-2	-	-	-
95	25 x 4	L 3 C - 95254	90	AF-2	-	-	-
95	25 x 5	L 3 C - 95255	90	AF-2	-	-	-
95	25 x 6	L 3 C - 95256	115	AF-2	-	-	-
100	25 x 4	L 3 C - 100254	90	AF-2	-	-	-
100	25 x 5	L 3 C - 100255	90	AF-2	-	-	-
100	25 x 6	L 3 C - 100256	115	AF-2	-	-	-
120	25 x 5	L 3 C - 120255	90	AF-2	-	-	-
120	25 x 6	L 3 C - 120256	115	AF-2	-	-	-
120	30 x 4	L 3 C - 120304	115	AF-2	-	-	-
150	25 x 6	L 3 C - 150256	115	AF-2	-	-	-
150	30 x 4	L 3 C - 150304	115	AF-2	-	-	-
150	40 x 4	L 3 C - 150404	115	AF-2	-	-	-
185	30 x 6	L 3 C - 185306	150	AF-2	-	-	-
185	40 x 4	L 3 C - 185404	150	AF-2	-	-	-
185	50 x 4	L 3 C - 185504	150	AF-2	-	-	-
240	50 x 4	L 3 C - 240504	200	AF-2	-	-	-
240	50 x 6	L 3 C - 240506	250	AF-2	-	-	-
300	50 x 6	L 3 C - 300506	300	AF-2	-	-	-
300	50 x 8	L 3 C - 300508	400	AF-2	-	-	-



= 1, 2







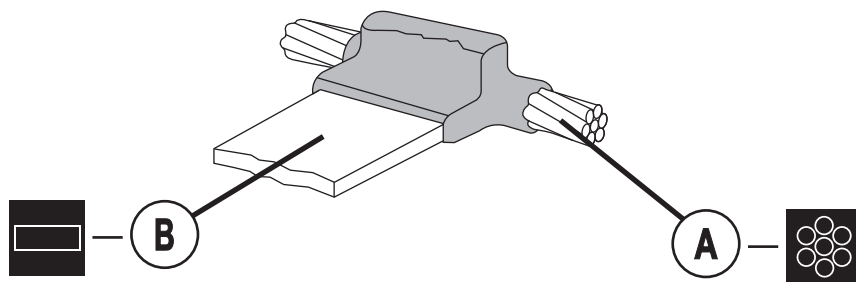

= 5, 15, 16, 17, 18

B * Nominal - Veja página

Mire la pagina
See page

9 - 8



A mm ²	B mm x mm				MINI 		
10	20 x 2	L 5 C - 10202	45	AF-2	L 5 B - 10202	45	AF-1
16	20 x 2	L 5 C - 16202	45	AF-2	L 5 B - 16202	45	AF-1
16	20 x 3	L 5 C - 16203	45	AF-2	L 5 B - 16203	45	AF-1
16	25 x 3	L 5 C - 16253	65	AF-2	L 5 B - 16253	65	AF-1
25	20 x 2	L 5 C - 25202	45	AF-2	L 5 B - 25202	45	AF-1
25	20 x 3	L 5 C - 25203	45	AF-2	L 5 B - 25203	45	AF-1
25	25 x 3	L 5 C - 25253	65	AF-2	L 5 B - 25253	65	AF-1
35	20 x 2	L 5 C - 35202	45	AF-2	L 5 B - 35202	45	AF-1
35	20 x 3	L 5 C - 35203	45	AF-2	L 5 B - 35203	45	AF-1
35	25 x 3	L 5 C - 35253	65	AF-2	L 5 B - 35253	65	AF-1
50	20 x 3	L 5 C - 50203	65	AF-2	L 5 B - 50203	65	AF-1
50	25 x 2	L 5 C - 50252	65	AF-2	L 5 B - 50252	65	AF-1
50	25 x 3	L 5 C - 50253	65	AF-2	L 5 B - 50253	65	AF-1
70	25 x 3	L 5 C - 70253	90	AF-2	-	-	-
70	25 x 4	L 5 C - 70254	115	AF-2	-	-	-
70	25 x 6	L 5 C - 70256	115	AF-2	-	-	-
95	25 x 4	L 5 C - 95254	150	AF-2	-	-	-
95	25 x 5	L 5 C - 95255	150	AF-2	-	-	-
95	25 x 6	L 5 C - 95256	150	AF-2	-	-	-
100	25 x 4	L 5 C - 100254	150	AF-2	-	-	-
100	25 x 5	L 5 C - 100255	150	AF-2	-	-	-
100	25 x 6	L 5 C - 100256	150	AF-2	-	-	-
120	25 x 5	L 5 C - 120255	150	AF-2	-	-	-
120	25 x 6	L 5 C - 120256	150	AF-2	-	-	-
120	30 x 5	L 5 C - 120305	200	AF-2	-	-	-
150	25 x 6	L 5 C - 150256	200	AF-2	-	-	-
150	30 x 5	L 5 C - 150305	200	AF-2	-	-	-
150	40 x 5	L 5 C - 150405	250	AF-2	-	-	-
185	30 x 6	L 5 C - 185306	250	AF-2	-	-	-
185	40 x 5	L 5 C - 185405	250	AF-2	-	-	-
185	50 x 5	L 5 D - 185505	300	AF-3	-	-	-
240	50 x 5	L 5 D - 240505	300	AF-3	-	-	-
240	50 x 6	L 5 D - 240506	400	AF-3	-	-	-
300	50 x 6	L 5 D - 300506	500	AF-3	-	-	-
300	50 x 8	L 5 D - 300508	500	AF-3	-	-	-

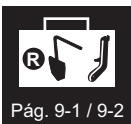

= 1, 2



= 5, 15, 16, 17, 18

B * Nominal - Veja página
Mire la pagina
See page

9 - 8



Bogotá Sala de Ventas

Carrera 12 No 13 - 46
PBX: 6013360755 - 6013412439
Celular: 312 3055335

Centro de Distribución

Carrera 18 No 19A - 36
PBX: 6013360755 EXT: 2101



SEÇÃO
SECCIÓN
SECTION



CONEXÃO CABO A BARRA DE AÇO



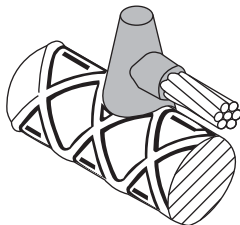
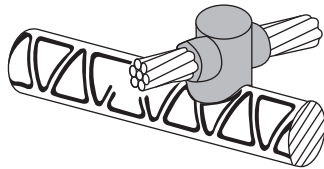
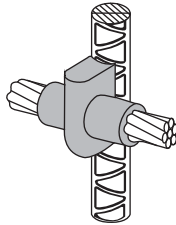
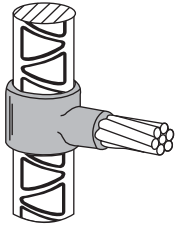
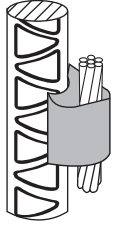

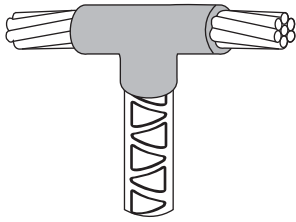
CONEXIÓN CABLE A BARRA DE ACERO

COPPER CABLE TO REBAR CONNECTION

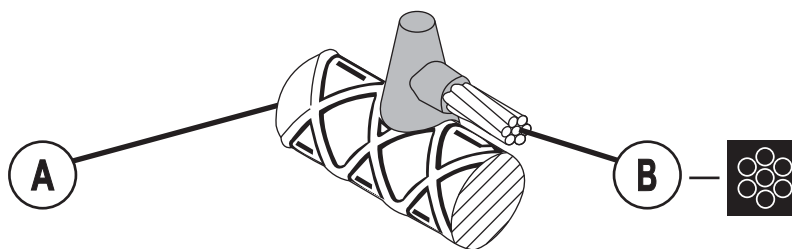
<p>R1</p>  <p><i>PÁG. 8 - 1</i></p>	<p>R2</p>  <p><i>PÁG. 8 - 2</i></p>
<p>R3</p>  <p><i>PÁG. 8 - 3</i></p>	<p>R4</p>  <p><i>PÁG. 8 - 4</i></p>
<p>R5</p>  <p><i>PÁG. 8 - 4</i></p>	<p>R6</p>  <p><i>PÁG. 8 - 5</i></p>
<p>R7</p>  <p><i>PÁG. 8 - 5</i></p>	

R1



A Ø	B mm ²				
3/8"	25	R 1 B - 9 25	32	-	AF-1
	35	R 1 B - 9 35	45	-	AF-1
	50	R 1 C - 9 50	90	-	AF-2
	70	R 1 C - 9 70	90	-	AF-2
	95	R 1 C - 9 95	115	-	AF-2
1/2"	25	R 1 A - 12 25	32	GX-3A	-
	35	R 1 A - 12 35	45	GX-3A	-
	50	R 1 C - 12 50	90	GX-2B	AF-2
	70	R 1 C - 12 70	90	GX-2B	AF-2
	95	R 1 C - 12 95	115	GX-2B	AF-2
5/8"	25	R 1 A - 16 25	32	GX-3A	-
	35	R 1 A - 16 35	45	GX-3A	-
	50	R 1 H - 16 50	90	GX-2B	-
	70	R 1 H - 16 70	90	GX-2B	-
	95	R 1 H - 16 95	115	GX-2B	-
3/4"	25	R 1 A - 19 25	32	GX-2B	-
	35	R 1 A - 19 35	45	GX-2B	-
	50	R 1 H - 19 50	90	GX-4C	-
	70	R 1 H - 19 70	90	GX-4C	-
	95	R 1 H - 19 95	115	GX-4C	-
7/8"	25	R 1 A - 22 25	32	GX-3B	-
	35	R 1 A - 22 35	45	GX-3B	-
	50	R 1 H - 22 50	90	GX-4A	-
	70	R 1 H - 22 70	90	GX-4A	-
	95	R 1 H - 22 95	115	GX-4A	-
1"	35	R 1 A - 25 35	45	GX-3B	-
	50	R 1 H - 25 50	90	GX-4A	-
	70	R 1 H - 25 70	90	GX-4A	-
	95	R 1 H - 25 95	115	GX-4A	-
1.1/8"	35	R 1 A - 28 35	45	GX-3B	-
	50	R 1 H - 28 50	90	GX-4A	-
	70	R 1 H - 28 70	90	GX-4A	-
	95	R 1 H - 28 95	115	GX-4A	-
1.1/4"	35	R 1 A - 32 35	45	GX-3B	-
	50	R 1 H - 32 50	90	GX-4A	-
	70	R 1 H - 32 70	90	GX-4A	-
	95	R 1 H - 32 95	115	GX-4A	-







= 1, 2, 13/14

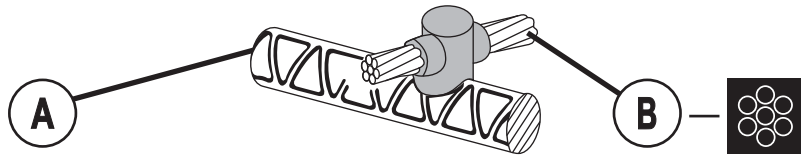

= 5, 15, 16, 17, 18







A Ø	B mm ²			
3/8"	25	R 2 M - 9 25	65	GX-2B
	35	R 2 M - 9 35	90	GX-2B
	50	R 2 M - 9 50	115	GX-2B
	70	R 2 M - 9 70	115	GX-2B
	95	R 2 M - 9 95	150	GX-2B
1/2"	25	R 2 M - 12 25	65	GX-2B
	35	R 2 M - 12 35	90	GX-2B
	50	R 2 M - 12 50	115	GX-2B
	70	R 2 M - 12 70	115	GX-2B
	95	R 2 M - 12 95	150	GX-2B
5/8"	25	R 2 M - 16 25	65	GX-2B
	35	R 2 M - 16 35	90	GX-2B
	50	R 2 M - 16 50	115	GX-2B
	70	R 2 M - 16 70	115	GX-2B
	95	R 2 M - 16 95	150	GX-2B
3/4"	25	R 2 M - 19 25	65	GX-4C
	35	R 2 M - 19 35	90	GX-4C
	50	R 2 M - 19 50	115	GX-4C
	70	R 2 M - 19 70	115	GX-4C
	95	R 2 M - 19 95	150	GX-4C
7/8"	25	R 2 M - 22 25	65	GX-4C
	35	R 2 M - 22 35	90	GX-4C
	50	R 2 M - 22 50	115	GX-4C
	70	R 2 M - 22 70	115	GX-4C
	95	R 2 M - 22 95	150	GX-4C
1"	35	R 2 M - 25 35	90	GX-4C
	50	R 2 M - 25 50	115	GX-4A
	70	R 2 M - 25 70	115	GX-4A
	95	R 2 M - 25 95	150	GX-4A
1.1/8"	35	R 2 M - 28 35	65	GX-4C
	50	R 2 M - 28 50	115	GX-4A
	70	R 2 M - 28 70	115	GX-4A
	95	R 2 M - 28 95	150	GX-4A
1.1/4"	35	R 2 M - 32 35	65	GX-4C
	50	R 2 M - 32 50	115	GX-4A
	70	R 2 M - 32 70	115	GX-4A
	95	R 2 M - 32 95	150	GX-4A

 = 1, 2, 13/14
 Pág. 9-1 / 9-2

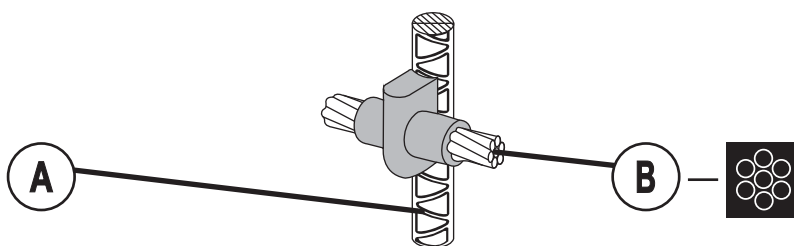
 = 5, 15, 16, 17, 18
 Pág. 9-1 / 9-2

R3



A ∅	B mm ²				
3/8"	25	R 3 E - 9 25	90	GX-2A	AF-2
	35	R 3 E - 9 35	90	GX-2A	AF-2
	50	R 3 E - 9 50	115	GX-2A	AF-2
	70	R 3 E - 9 70	115	GX-2A	AF-2
	95	R 3 E - 9 95	150	GX-2A	AF-2
1/2"	25	R 3 E - 12 25	90	GX-2A	AF-2
	35	R 3 E - 12 35	90	GX-2A	AF-2
	50	R 3 E - 12 50	115	GX-2A	AF-2
	70	R 3 E - 12 70	115	GX-2A	AF-2
	95	R 3 E - 12 95	150	GX-2A	AF-2
5/8"	25	R 3 E - 16 25	90	GX-2A	AF-2
	35	R 3 E - 16 35	90	GX-2A	AF-2
	50	R 3 E - 16 50	115	GX-2A	AF-2
	70	R 3 E - 16 70	115	GX-2A	AF-2
	95	R 3 E - 16 95	150	GX-2A	AF-2
3/4"	25	R 3 E - 19 25	90	GX-4B	AF-2
	35	R 3 E - 19 35	90	GX-4B	AF-2
	50	R 3 E - 19 50	115	GX-4B	AF-2
	70	R 3 E - 19 70	115	GX-4B	AF-2
	95	R 3 E - 19 95	150	GX-4B	AF-2
7/8"	25	R 3 E - 22 25	90	GX-4B	AF-2
	35	R 3 E - 22 35	90	GX-4B	AF-2
	50	R 3 E - 22 50	115	GX-4B	AF-2
	70	R 3 E - 22 70	115	GX-4B	AF-2
	95	R 3 E - 22 95	150	GX-4B	AF-2
1"	35	R 3 E - 25 35	90	GX-4B	AF-2
	50	R 3 E - 25 50	115	GX-4B	AF-2
	70	R 3 E - 25 70	115	GX-4B	AF-2
	95	R 3 E - 25 95	150	GX-4B	AF-2
1.1/8"	35	R 3 E - 28 35	90	GX-4B	AF-2
	50	R 3 E - 28 50	115	GX-4B	AF-2
	70	R 3 E - 28 70	115	GX-4B	AF-2
	95	R 3 E - 28 95	150	GX-4B	AF-2
1.1/4"	35	R 3 E - 32 35	90	GX-4B	AF-2
	50	R 3 E - 32 50	115	GX-4B	AF-2
	70	R 3 E - 32 70	115	GX-4B	AF-2
	95	R 3 E - 32 95	150	GX-4B	AF-2

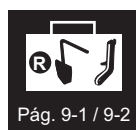

= 1, 2, 13/14



= 5, 15, 16, 17, 18

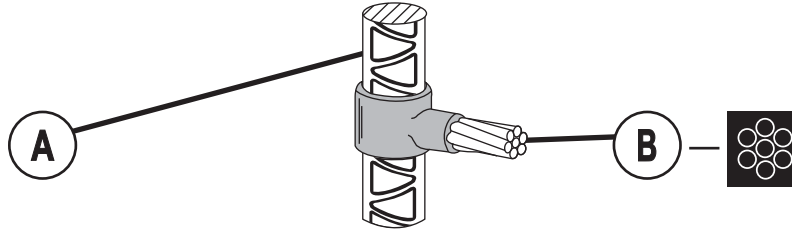

A Ø	B mm ²				
1/2"	25	R 4 R - 12 25	65	GX-2A	AF-2
	35	R 4 R - 12 35	65	GX-2A	AF-2
	50	R 4 R - 12 50	115	GX-2A	AF-2
	70	R 4 R - 12 70	115	GX-2A	AF-2
	95	R 4 R - 12 95	150	GX-2A	AF-2
5/8"	25	R 4 R - 16 25	65	GX-2A	AF-2
	35	R 4 R - 16 35	65	GX-2A	AF-2
	50	R 4 R - 16 50	115	GX-2A	AF-2
	70	R 4 R - 16 70	115	GX-2A	AF-2
	95	R 4 R - 16 95	150	GX-2A	AF-2
3/4"	25	R 4 R - 19 25	65	GX-2A	AF-2
	35	R 4 R - 19 35	65	GX-2A	AF-2
	50	R 4 R - 19 50	115	GX-2A	AF-2
	70	R 4 R - 19 70	115	GX-2A	AF-2
	95	R 4 R - 19 95	150	GX-2A	AF-2
1"	35	R 4 E - 25 35	65	GX-2A	AF-2
	50	R 4 E - 25 50	115	GX-2A	AF-2
	70	R 3 E - 25 70	115	GX-2A	AF-2
	95	R 3 E - 25 95	150	GX-2A	AF-2



= 1, 2, 13/14

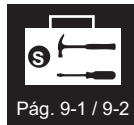

= 5, 15, 16, 17, 18

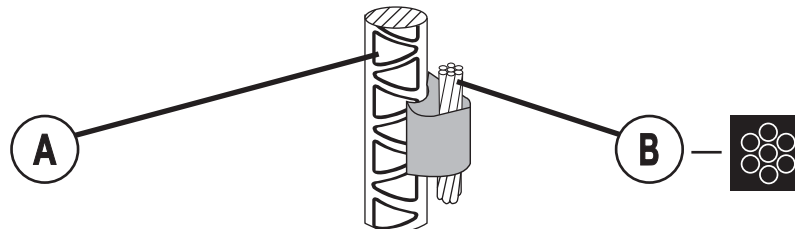

A Ø	B mm ²			
1/2"	25	R 5 E - 12 25	90	LA-3
	35	R 5 E - 12 35	90	LA-3
	50	R 5 E - 12 50	150	LA-3
	70	R 5 E - 12 70	150	LA-3
	95	R 5 E - 12 95	200	LA-3
5/8"	25	R 5 E - 16 25	90	LA-3
	35	R 5 E - 16 35	90	LA-3
	50	R 5 E - 16 50	150	LA-3
	70	R 5 E - 16 70	150	LA-3
	95	R 5 E - 16 95	200	LA-3



= 1, 2, 13



= 5, 15, 16, 17, 18

R6

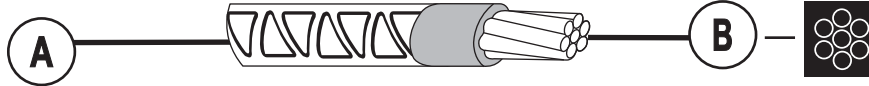

A Ø	B mm ²				
3/8"	25	R 6 B - 9 25	65	LA-3	AF-1
	35	R 6 B - 9 35	65	LA-3	AF-1
	50	R 6 C - 9 50	90	LA-3	AF-2
	70	R 6 C - 9 70	115	LA-3	AF-2
	95	R 6 C - 9 95	115	LA-3	AF-2
1/2"	25	R 6 C - 12 25	65	LA-3	AF-2
	35	R 6 C - 12 35	90	LA-3	AF-2
	50	R 6 C - 12 50	90	LA-3	AF-2
	70	R 6 C - 12 70	150	LA-3	AF-2
	95	R 6 C - 12 95	150	LA-3	AF-2
5/8"	25	R 6 C - 16 25	90	LA-3	AF-2
	35	R 6 C - 16 35	90	LA-3	AF-2
	50	R 6 C - 16 50	115	LA-3	AF-2
	70	R 6 C - 16 70	150	LA-3	AF-2
	95	R 6 C - 16 95	150	LA-3	AF-2



R7

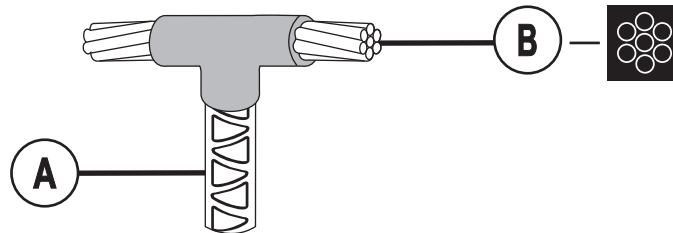



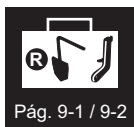



A Ø	B mm ²				
3/8"	25	R 7 B - 9 25	65	LA-3	AF-1
	35	R 7 B - 9 35	65	LA-3	AF-1
	50	R 7 C - 9 50	90	LA-3	AF-2
	70	R 7 C - 9 70	90	LA-3	AF-2
	95	R 7 C - 9 95	115	LA-3	AF-2
1/2"	25	R 7 B - 12 25	65	LA-3	AF-1
	35	R 7 B - 12 35	65	LA-3	AF-1
	50	R 7 C - 12 50	90	LA-3	AF-2
	70	R 7 C - 12 70	90	LA-3	AF-2
	95	R 7 C - 12 95	115	LA-3	AF-2
5/8"	25	R 7 B - 16 25	65	LA-3	AF-1
	35	R 7 C - 16 35	90	LA-3	AF-2
	50	R 7 C - 16 50	90	LA-3	AF-2
	70	R 7 C - 16 70	115	LA-3	AF-2
	95	R 7 C - 16 95	115	LA-3	AF-2
3/4"	25	R 7 C - 19 25	90	LA-3	AF-2
	35	R 7 C - 19 35	90	LA-3	AF-2
	50	R 7 C - 19 50	115	LA-3	AF-2
	70	R 7 C - 19 70	115	LA-3	AF-2
	95	R 7 C - 19 95	115	LA-3	AF-2

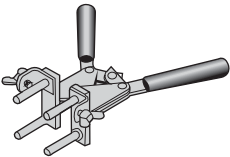

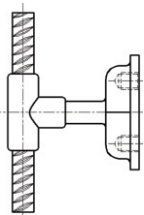
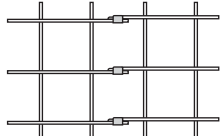
SEÇÃO
SECCIÓN
SECTION

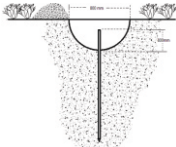
9

<p>ACESSORIOS ACCESORIOS ACCESSORIES</p>  <p>PÁG. 9 - 1 ; 9 - 2</p>	<p>BARRA EQUIPOTENCIAL BARRA DE EQUIPOTENCIALIZACION GROUND BAR</p>  <p>PÁG. 9 - 3</p>
<p>PLACA DE ATERRAMENTO TOMA TIERRA GROUND PLATE</p>  <p>PÁG. 9 - 4</p>	<p>MALHA PRÉ FABRICADA MALLA PRE FABRICADA PRE FABRICATED GRID</p>  <p>PÁG. 9 - 5</p>
<p>TERMINAIS DE COBRE TERMINALES DE COBRE COPPER LUGS</p>  <p>PÁG. 9 - 6</p>	<p>CABO DE ATERRAMENTO CONDUCTOR DE PUESTA TIERRA GROUND CONDUCTOR</p> <p>PÁG. 9 - 7</p>
<p>LAMINA & BARRA DE COBRE FLEJE Y BARRA DE COBRE STRIP AND COPPER BAR</p>  <p>PÁG. 9 - 8</p>	<p>FASTGEL PARA BAIXAR A RESISTIVIDADE DO SOLO FASTGEL PARA BAJAR LA RESISTIVIDAD DEL SUELO FASTGEL TO REDUCE THE GROUND RESISTANCE</p>  <p>PÁG. 9 - 9 / 9 - 10 / 9 - 11</p>
<p>HASTE DE ATERRAMENTO BARRA PUESTA TIERRA GROUND ROD</p>  <p>PÁG. 9 - 12</p>	<p>CORDOALHA DE ATERRAMENTO TRENZA PARA ATERRAMIENTO GROUND BRAID</p>  <p>PÁG. 9 - 13</p>



Bogotá Sala de Ventas



Carrera 12 No 13 - 46
PBX: 6013360755 - 6013412439
Celular: 312 3055335

Centro de Distribución





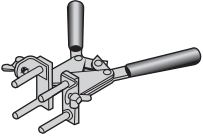
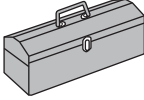
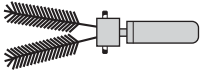
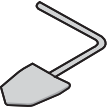
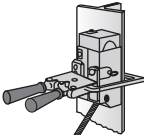

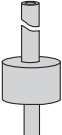
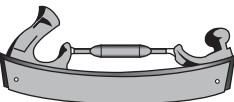

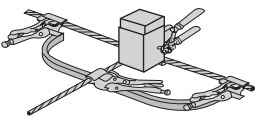

Carrera 18 No 19A - 36
PBX: 6013360755 EXT: 2101

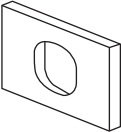
Accesorios

Accessories

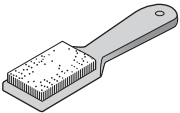
	1	AC-32 AC-R	Ignitor Fastweld para partida do pó de ignição Pedra para reposição	Chispero/encendedor Fastweld para encender el polvo de ignición Piedra para repuesto	Flint ignitors are used to ignite the starting material Replacement Flints
	2	AF-1 AF-2 AF-3	Alicete para fechar e travar molde - CLASSE B (MINI) - CLASSE C - CLASSE D	Manija tenaza para cerrar y trabar moldes - CLASE B (MINI) - CLASE C - CLASE D	Handle clamps to close and lock the mould - B KEY (MINI) - C KEY - D KEY
	3	CF-1 CF-2 CF-3	Caixa de ferramentas vazia Caixa com ferramentas: LM-1, LI-2, CHF-4, AL-18, EP-3 LM-1, LM-2, LI-2, CHF-4, AL-18, EP-3 MV-18/2, LA-3, AC-32, OP-26, LRT-2, PLM-25	Caja para herramientas Caja con herramientas LM-1, LI-2, CHF-4, AL-18, EP-3 LM-1, LM-2, LI-2, CHF-4, AL-18, EP-3 MV-18/2, LA-3, AC-32, OP-26, LRT-2, PLM-25	Tool box empty Tool box with LM-1, LI-2, CHF-4, AL-18, EP-3 LM-1, LM-2, LI-2, CHF-4, AL-18, EP-3 MV-18/2, LA-3, AC-32, OP-26, LRT-2, PLM-25
	4	ED-1 ED-R	Escova dupla p/limpeza de cabo Escova de reposição	Cepillo doble para limpiar cables Cepillo de reposición	Cable cleaning brush Replacement brush
	5	LM-1 LM-2	Limpador para moldes que utilizam: Cartucho nr. 65 e menores Cartucho nr. 90 e maiores	Limpiador para moldes que utilizan: Polvo de soldadura 65 y menores Polvo de soldadura 90 y mayores	Slag cleaner for mould: weld metal size 65 & smaller weld metal size 90& larger
	6	GM - 2 GM - 3 GM - 4	Grampo para mola para solda em tubo até 10" Grampo para molde em soldagem á superfície vertical para molde C Para mini molde B	Soporte com mola para soldadura en tube hasta 10" Pinza para molde en soldagem a superfície vertical molde C Para mini molde B	Vertical surface mold clamp for C key For mini mold "B" key
	7	GH-6	Grampo para alinhamento de hastes em solda tipo "GG"	Pinza para alinear jabalina para la soldadura "GG"	Ground rod splice clamp for "GG" connections
	8	LC-12 LC-58 LC-34	Luva de proteção para cravação de Hastes de 1/2" Hastes de 5/8" Hastes de 3/4"	Mango de protector para varilla 1/2" varilla 5/8" varilla 3/4"	Head ground rod protect sleeve: 1/2" ground rod driving 5/8" ground rod driving 3/4" ground rod driving
	9	CRH-18	Ferramenta para cravação de hastes diâmetro até 3/4"	Herramienta para clavar manualmente la varilla diametro hasta 3/4"	Ground rod manual driving
	10	RA-32	Raspador para limpeza de superfície metálica	Pulidor para limpiar superficie metálica	remove rust rasp for a metallic surface

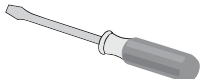
Acessórios

	11	GC-7	Grampo para fixar cabos tensionados	Pinza para fijar cables en tension	Cable fixed clamp for tensioned cables
	12	MV-18 MV-18/2	Massa vedamolde, utilizada para vedar espaços vazios entre condutor superfície para evitar vazamento de material Embalagem com 1Kg Embalagem com 500 g	Masilla de obturación para evitar escape de metal fundido presentaciones Embalaje con 1 Kg Embalaje con 500 g	Mold sealer, ideal for sealing to hinder the weld metal empty 1 Kg package ½ Kg package
	13	LA-3	Lamina de cobre para adaptação de cabos em moldes de menor diâmetro, ou soldas em barras de construção civil	Laminilla de cobre para adaptar cables de diametro más pequeño a moldes de diametro más grandes o para soldaduras en barra de hierro corrugado	Copper flake to adjust the cable in mould for large diameter. It is required in connections cable to rebar
	14	GX	Gaxeta de fibrocaramica ou lamina de cobre para se utilizar em conexões entre cabos a barras de construção civil com ranhuras	Gaxeta de fibrocaramica o lamina de cobre para se utilizar en las soldaduras entre cables a barra de hierro con nervuras	Ceramic PACKING or copper flake is required on all rebar connection
	15	OP-26	Óculos de segurança FASTWELD	Anteojos de seguridad	Safety glasses
	16	LRT-2	Luvas de segurança	Guantes de seguridad	Safety gloves
	17	PLM-25	Pincel para limpeza do molde	Pincel para limpiar el molde	Cleaner mold brush
	18	EP-3	Escova plana de aço para limpar cabos, barramentos, hastes	Cepillo, metalico para limpiar cables, barras, varillas, etc	Card cloth brush for cleaning conductors, bars and ground rods
	19	AL-18	Alicate comum	Tenaza comum	Nippeas
	20	LI-2	Lima	Lima	Rasp
	21	CHF-4	Chave de fenda	Destornillador	Screw-Drive
	22	MPF-32C	Maçarico portátil completo	Soplete portátil	Portable propane torch
	23	BMF-32	Bico de reposição	Bico para soplete	Torch head replacement
	24	GRF-32	Refil de gas	Recarga de gas	Propane replacement
			Não pode ser despachado por avião	No es posible envio por avion	Can not be shipped by air

BARRA DE TIERRA FASTWELD

FASTWELD GROUND BAR

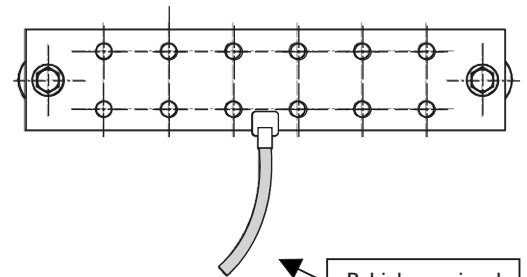
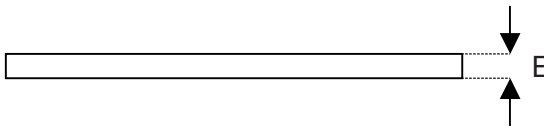
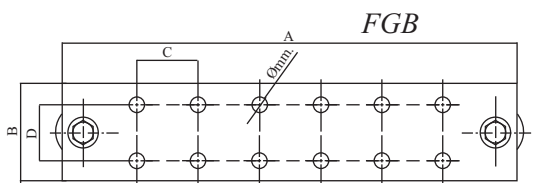
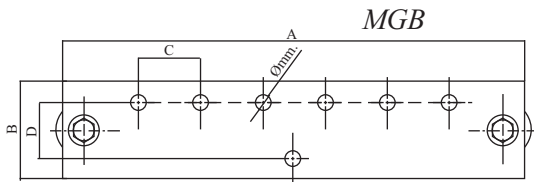
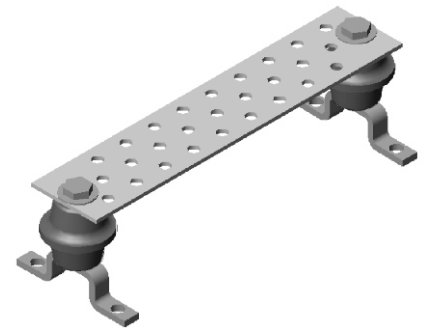

Rabicho opcional
Optional Pigtail

Como especificar
How to specify

1 - Inclua ao código da barra, a bitola e comprimento do cabo (m)
Incluya al código de la placa, la sección y largo del cable (m)
Insert to the cable size and length to the plate code, ex:

cabo / cable mm² cabo / cable AWG
MGB - 12B - 95 / 3 MGB - 12B - 100A / 3

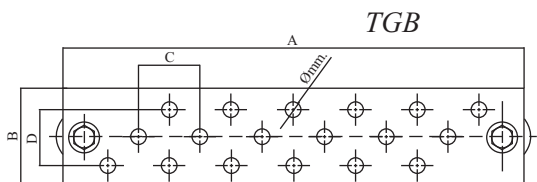
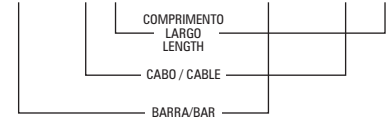

CAT. REFERÊNCIA	FUROS AGUJEROS HOLES	A mm	B mm	C mm	D mm	ø mm	E mm
FGB-8A	8	130	38,1	20,5	19,5	8,50	4,76
FGB-12B	12	203	38,1	25,5	19,5	10	4,76
FGB-18C	18	360	63,5	30	30	8,50	6,35
FGB-22F	22	420	63,5	30	30	11,11	6,35
MGB-7 A	7	300	63,5	35	31,5	6,35	6,35
TGB-26 A	26	385	101,2	40	30	12	6,35
TGB-24 A	24	360	76,2	33,6	23	11,11	6,35

DISPONÍVEIS EM OUTRAS DIMENSÕES OU DE ACORDO COM SEU PROJETO
DISPONIBLE EN OTRAS DIMENSIONES O DE ACUERDO CON SU PROYECTO
AVAILABLE IN OTHER SIZES OR ACCORDING TO YOUR PROJECT

PLACA DE TIERRA FASTWELD

FASTWELD GROUND PLATE

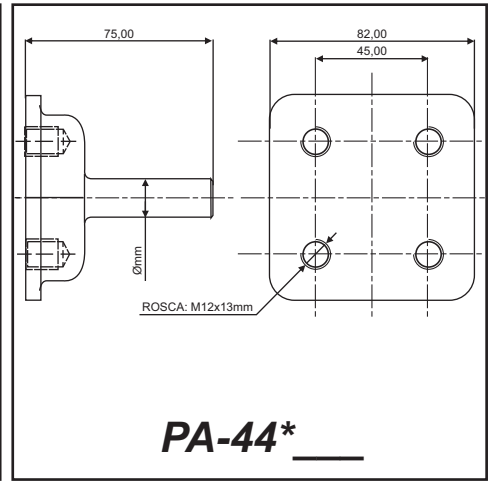
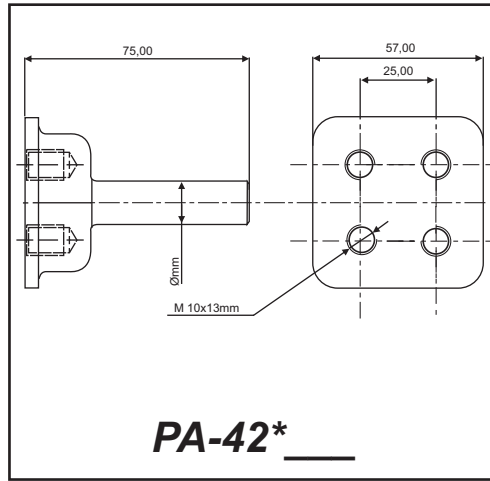
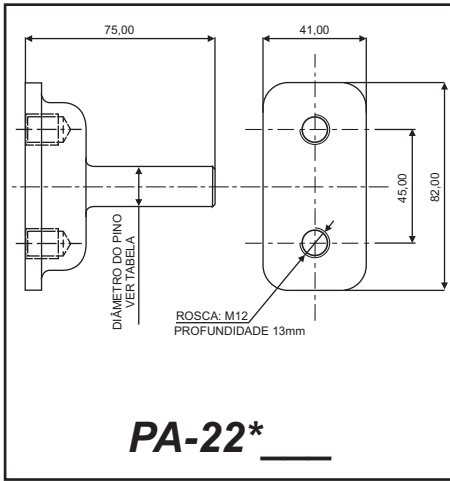

Inclua ao codigo da placa, a bitola do cabo equivalente exemplo: Cabo 70mm² – Placa PA-42 – codigo da placa PA-4270
 Incluye al codigo de la placa, la seccion del cable equivalente ejemplo: Cable 70mm² – Placa PA-42:codigo de la placa PA-4270
 Insert to the plate code, the equivalent cable, for example: 2/0AWG – Plate PA-42 – the plate reference is PA-4270A

Conexão tipo
 Conexión tipo
 Connection type

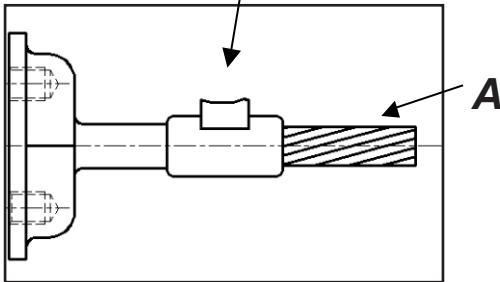

Conexão tipo
 Conexión tipo
 Connection type

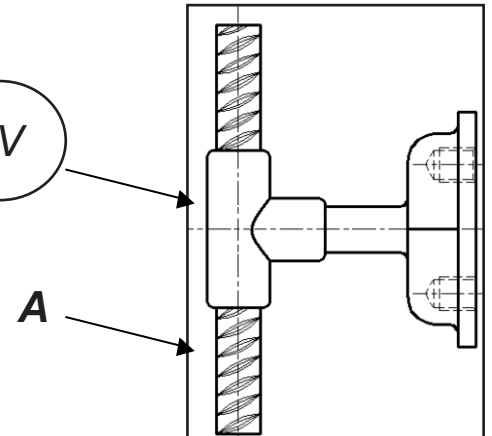
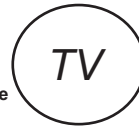

A		Conexão Conexión tipo Connection type			SV			Conexão Conexión tipo Connection type			TV		
25mm ²	PA-2225	PA-4225	PA-4425	SVC-25	32	AF-2	TVR-2525	65	AF-2				
35mm ²	PA-2235	PA-4235	PA-4435	SVC-35	32	AF-2	TVR-3535	65	AF-2				
50mm ²	PA-2250	PA-4250	PA-4450	SVC-50	45	AF-2	TVR-5050	90	AF-2				
70mm ²	PA-2270	PA-4270	PA-4470	SVC-70	65	AF-2	TVR-7070	90	AF-2				
95mm ²	PA-2295	PA-4295	PA-4495	SVC-95	90	AF-2	TVR-9595	150	AF-2				
120mm ²	PA-22120	PA-42120	PA-44120	SVC-120	115	AF-2	TVR-120120	150	AF-2				
BARRA DE ALUMINIO ALUMINUM BAR	3/8"	PA-2250	PA-4250	PA-4450	SVC-509	45	AF-2	TVR-509	115	AF-2			
	1/2"	PA-2270	PA-4270	PA-4470	SVC-7012	90	AF-2	TVR-9512	150	AF-2			
	5/8"	PA-2295	PA-4295	PA-4495	SVC-9516	115	AF-2	TVR-9516	150	AF-2			
	3/4"	PA-22120	PA-42120	PA-44120	SVC-12019	150	AF-2	TVR-12019	150	AF-2			

MALLA PRE FABRICADA

FASTWELD FABRICATED MESH

A FASTWELD fabrica a malha de acordo com as especificações do seu projeto ou desenho, qualquer dimensão ou geometria. As malhas podem ser produzidas com cabos (malha de aterramento), com fios ou **fitas de cobre** (malhas de equalização de potencial ou malha de referência de sinais).

FASTWELD fabrica la malla de acuerdo con las especificaciones de su proyecto o diseño, en cualquier medida o forma geométrica. Las mallas pueden ser construidas con cables (malla de aterramiento), con hilos o **flejes de cobre** (mallas de equalización de potenciales o malla de referencia de señales)

Fastweld produces the mash according to your specification, project or drawing, with any dimension or geometry. The mesh can be made with cables (grounding mash), with wires or **copper tapes** (potential equalization mesh or signal reference grid).

Malha aberta - Fio ou fita cobre
Malla abierta - Hilo o fleje de cobre
Open Mesh - wire or copper strip

Malha fechada
Malla cerrada
Closed mesh

Solda Exotérmica
Soldadura exotermica
Exothermic weld

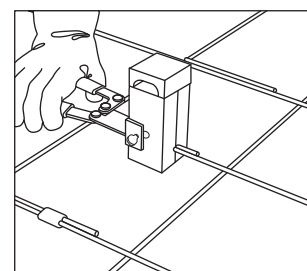
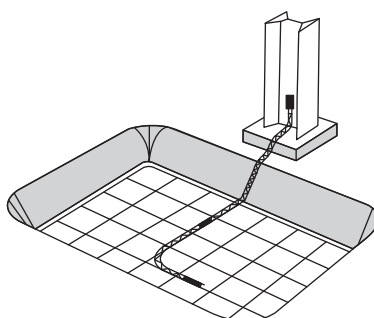
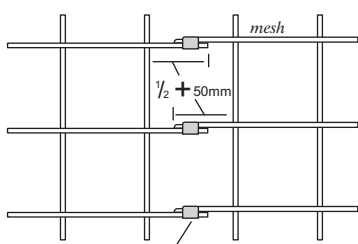

MALHA DE FITA DE COBRE - MALLA DE FLEJE DE COBRE - COPPER STRIP MESH

Mesh / reticulado

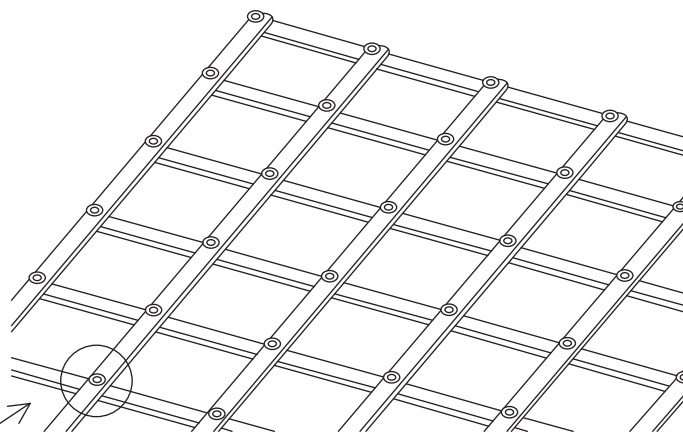
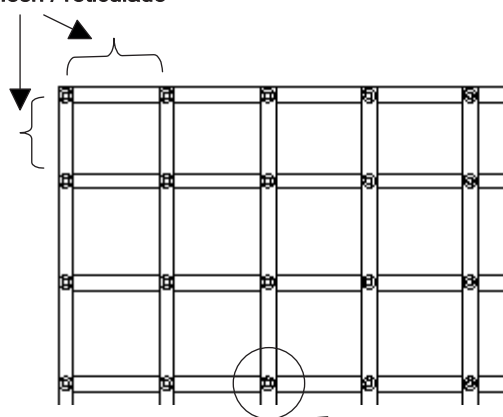

solda exotérmica / soldadura exotérmica
 exothermic weld (B8, B9)

Para especificar informe:

Largura e comprimento da malha

Material (lamina fio ou cabo)

Bitola, seção ou dimensão do material

Reticulado ou mesh

Para especificar informe:

Ancho y largo de la malla

Material (fleje, alambre o cable)

Calibre, sección o dimensión del material

Dimensión del mesh (reticulado)

To specify inform:

The lenght and width of mesh

Material (wire, cable or strip)

Size, section or dimension of material

Dimension of the mesh

	Mesh (cm)	Fio Cobre (mm)	Ref Malha	Molde para Emenda	Cart
Malha Aberta	20x20	10	MPV-10	PIT-1010	15
Malha Aberta	20x20	16	MPV-16	PIT-1616	25
Malha Fechada	30x30	10	MPT-10	N/A	N/A
Malha Fechada	30x30	16	MPT-16	N/A	N/A

TERMINAIS - TERMINALES - TERMINAL LUG

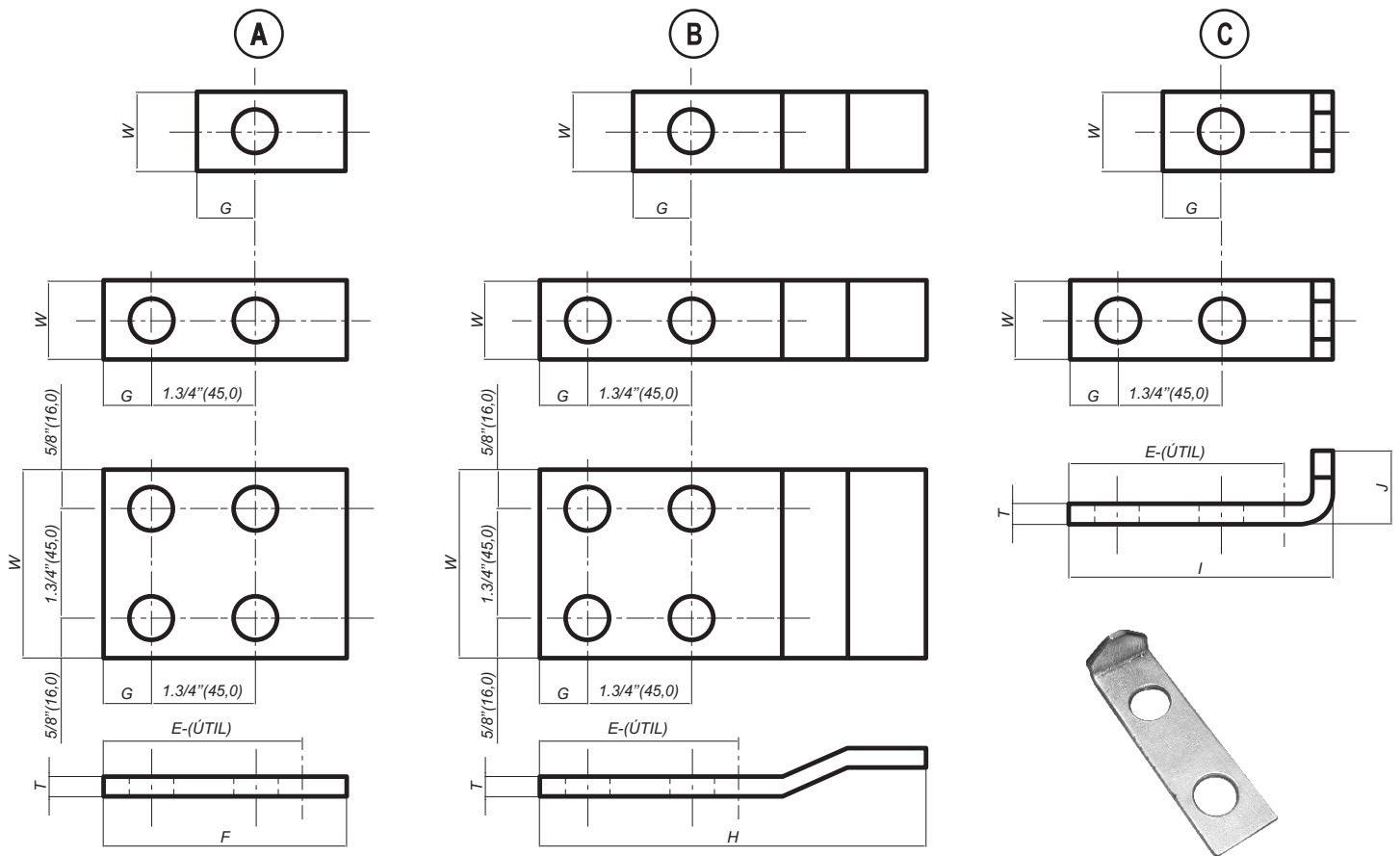

T x W	FUROS HOLES	Ø mm	A	B	C	DIMENSÕES - DIMENSION - DIMENSIÓN								CABO CABLE (mm ²)
						T	W	G	E	F	H	I	J	
1/8x1	1F	10	L2 TA 1F	L2 TA 1F OL	L1 TA 1F	1/8	1	12	22	60	79	28	16	70
	2F	12	L2 TA 2F	L2 TA 2F OL	L1 TA 2F	1/8	1	16	76	114	133	82	16	70
3/16x1	1F	12	L2 CB 1F	L2 CB 1F OL	L1 CB 1F	3/16	1	14	28	73	92	37	20	120
	2F	12	L2 CB 2F	L2 CB 2F OL	L1 CB 2F	3/16	1	16	76	120	140	85	20	120
1/4x1	1F	12	L2 SA 1F	L2 SA 1F OL	L1 SA 1F	1/4	1	16	28	76	92	40	22	150
	2F	12	L2 SA 2F	L2 SA 2F OL	L1 SA 2F	1/4	1	16	76	124	143	88	22	150
1/4x1.1/2	1F	16	L2 SB 1F	L2 SB 1F OL	L1 SB 1F	1/4	1-1/2	19	38	76	105	50	26	240
	2F	12	L2 SB 2F	L2 SB 2F OL	L1 SB 2F	1/4	1-1/2	16	76	124	143	88	26	240
1/4x2	2F	12	L2 SC 2F	L2 SC 2F OL	-	1/4	2	16	76	133	152	-	-	300
3/8x1.1/2	1F	16	L2 DB 1F	L2 DB 1F OL	-	3/8	1-1/2	19	38	95	120	-	-	350
	2F	12	L2 DB 2F	L2 DB 2F OL	-	3/8	1-1/2	16	76	146	178	-	-	350
3/8x2	1F	16	L2 DC 1F	L2 DC 1F OL	-	3/8	2	25	54	111	143	-	-	500
	2F	12	L2 DC 2F	L2 DC 2F OL	-	3/8	2	22	76	146	178	-	-	500
1/2x2	2F	12	L2 ZC 2F	L2 ZC 2F OL	-	1/2	2	16	76	146	178	-	-	725
1/4x3	4F	12	L2 SG 4F	L2 SG 4F OL	-	1/4	3	16	76	140	159	-	-	500
3/8x3	4F	12	L2 DG 4F	L2 DG 4F OL	-	3/8	3	16	76	152	178	-	-	725
1/2x3	4F	12	L2 ZG 4F	L2 ZG 4F OL	-	1/2	3	16	76	159	184	-	-	1000

CONDUTORES DE COBRE

COPPER CONDUCTOR

AWG CABLES			
AWG	DIAMETRO DIAMETER INCH. (pol.)	PESO WEIGHT Kg/Km	CÓD. MOLDE MOULD CODE
8	0,146	75,9	10A
6	0,184	121	16A
4	0,232	190	25A
3	0,26	240	30A
2	0,292	305	35A
1	0,332	385	40A
1/0	0,373	485	50A
2/0	0,419	611	70A
3/0	0,47	771	95A
4/0	0,528	972	100A
250	0,575	1150	120A
300	0,63	1280	150A
350	0,681	1610	185A
400	0,728	1840	200A
500	0,813	2300	240A
600	0,893	2760	300A
700	0,964	3220	350A
750	0,998	3450	380A
800	1.031	3680	400A
1000	1.152	4590	500A

SIZE mm2 EQUIVALENT CABLE			
mm2	DIAMETRO DIAMETER mm	PESO WEIGHT Kg/Km	CÓD. MOLDE MOULD CODE
10	4,08	90,3	10
16	5,1	143,2	16
25	6,18	227	25
35	7,5	314,8	35
50	8,9	428,6	50
70	10,35	619,5	70
95	12,36	859	95
120	14,5	1089	120
150	16,25	1338	150
185	17,75	1678	185
240	20,3	2210	240
300	22,5	2772	300
400	26,25	3545	400
500	28,84	4469	500

ABNT - NBR 6524/ NBR 6880

CONDUTORES SÓLIDOS - CONDUCTORES SOLIDOS - SOLID CONDUCTORS

AWG	DIAMETRO DIAMETER INCH. (pol.)	PESO WEIGHT Kg/Km	CÓD. MOLDE MOULD CODE
10	0,1019	46,827	6AS
8	0,1285	74,465	10AS
6	0,162	118,353	16AS
4	0,2043	188,228	25AS
3	0,2294	237,320	30AS
2	0,2576	299,254	35AS
1	0,2893	377,438	40AS
1/0	0,3249	476,045	50AS

mm2	DIAMETRO DIAMETER mm	PESO WEIGHT Kg/Km	CÓD. MOLDE MOULD CODE
6	2,763	53,400	6S
10	3,568	89,000	10S
16	4,500	142,400	16S
25	5,640	222,500	25S
35	6,700	311,500	35S
50		445,000	50S

EXEMPLO CODIFICAÇÃO MOLDE
EJEMPLO CODIFICACION DE MOLDE
MOULD CODE EXAMPLE

T1C - 100A 70A
 ↓ ↓
 4/0 AWG 2/0 AWG

BARRAS Y FLEJES DE COBRE

STRIP AND COPPER BAR

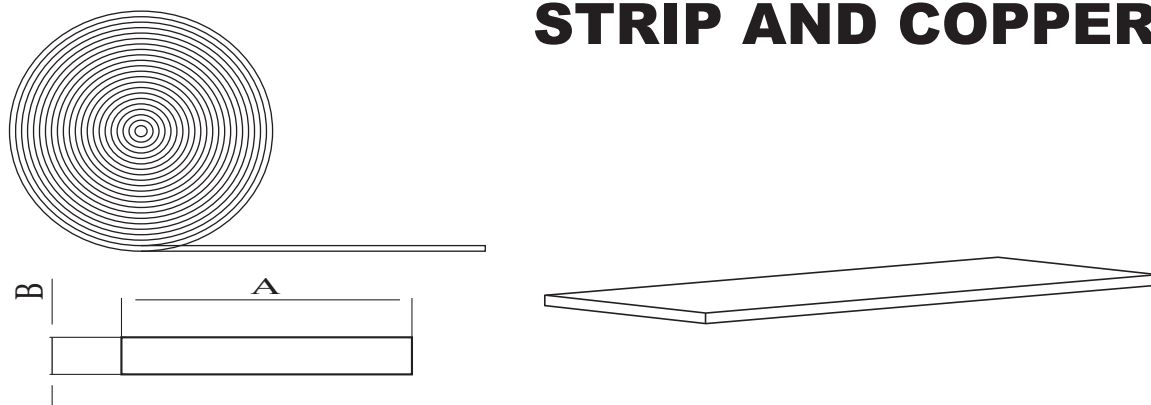

CÓDIGO FASTWELD CODE	LARGURA ANCHO WIDTH NOMINAL/mm	ESPESSURA ESPESSOR THICKNESS NOMINAL/mm	(A) LARGURA ANCHO REAL WIDTH ACTUAL	(B) ESPESSURA ESPESSOR REAL THICKNESS ACTUAL	PESO ESTIMADO ESTIMATED WEIGHT
LC-201	20	1	20mm	1mm	178,00
LC-251	25	1	25mm	1mm	222,50
LC-321	32	1	32mm	1mm	284,80
LC-401	40	1	40mm	1mm	356,00
LC-501	50	1	50mm	1mm	445,00
LC-631	63	1	63mm	1mm	560,70
LC-172	17,5	2	17,5mm	2mm	311,50
LC-202	20	2	20mm	2mm	356,00
LC-252	25	2	25mm	2mm	445,00
LC-352	35	2	35mm	2mm	623,00
BC-203	20	3	3/4"	1/8"	538,31
BC-253	25	3	1"	1/8"	716,61
BC-313	31	3	1.1/4"	1/8"	895,76
BC-383	38	3	1.1/2"	1/8"	1074,92
BC-403	40	3	1.3/4"	1/8"	1254,07
BC-503	50	3	2"	1/8"	1433,22
BC-254	25	4	1"	3/16"	1076,50
BC-304	30	4	1.1/4"	3/16"	1345,62
BC-384	38	4	1.1/2"	3/16"	1614,75
BC-444	44	4	1.3/4"	3/16"	1883,87
BC-504	50	4	2"	3/16"	2153,00
BC-256	25	6	1"	1/4"	1435,48
BC-306	30	6	1.1/4"	1/4"	1794,35
BC-386	38	6	1.1/2"	1/4"	2153,22
BC-446	44	6	1.3/4"	1/4"	2512,09
BC-506	50	6	2"	1/4"	2870,96
BC-508	50	8	1"	5/16"	1792,66
BC-608	60	8	2.1/2"	5/16"	4481,64

Espessura 1 e 2mm - disponível em rolos

Espesor 1 y 2mm - disponible en rollo

Thickness 1 and 2mm - available in coil

COBRE ELETROLÍTICO - COBRE ELECTROLÍTICO - ELECTROLITIC COPPER 99,9%

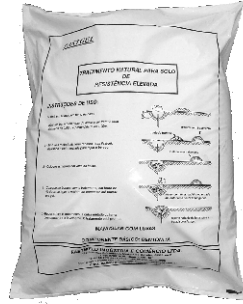

FASTGEL é um tratamento natural para solos de alta resistividade.

O Fastgel é um produto não tóxico e não agride o meio ambiente de acordo com ensaios feitos em laboratórios especializados.

O FASTGEL tem pH neutro o que evita a corrosão dos elementos.

É fornecido em embalagem contendo 12kg (1 dose)

Características técnicas:

- 1 - Densidade 0,000925g/mm³ (seco)
- 2 - Poder de inchamento proporcionando um maior e melhor contato entre haste/conductor a terra
- 3 - Baixa resistência e alta condutividade, podendo baixar a resistência do aterramento em até 75%
- 4 - Não é lixiviável ou seja, não se dispersa na época de chuvas.

FASTGEL és un tratamiento para suelos de alta resistencia.

El FASTGEL no és toxico y no contamina el medio ambiente conforme ensayos hechos en laboratórios especializados.

El FASTGEL tiene pH neutro o que evita la corrosion de los elementos.

Se suministra en bolsas de 12kg.

Características técnicas:

- 1 - Densidade 0,000925g/mm³ (seco)
- 2 - Se expande para proporcionar un mayor y mejor contacto entre la barra/conductor a la tierra.
- 3 - Baja resistencia y alta conductibilidad que permite bajar la resistencia de puesta a tierra hasta en un 75%
- 4 - No se dispersa con la lluvia

Fastgel is a natural treatment to soil with a high resistance available in 12kg bag.

Fastgel is a non-toxic product and it doesn't contaminate the environment according to the specialized laboratories certificate.

Made of bentonite and gypsun, Fastweld has a neuter pH that makes it a non-agressive element to the system where it is introduced.

Its main characteristics are:

- 1 - 0,000925g/mm³ Density (dry)
- 2 - It swells itself making a bigger and better contact between the rod/conductor and the soil
- 3 - Low resistance and high condutivity. It makes ground resistance 75% lower
- 4 - It does not disperse when it rains

ENSAIO DE CORROSÃO - ENSAYO DE CORROSION - CORROSION TEST

Ensaio corrosão
Ensayo de corrosion
Corosion test

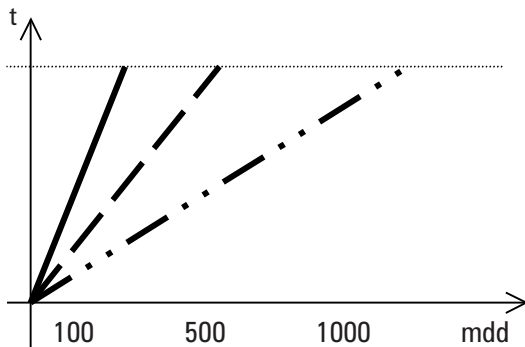

Perda de massa da haste em mg
Perdida de masa de la varilla en mg
Rod's mass loss in mg

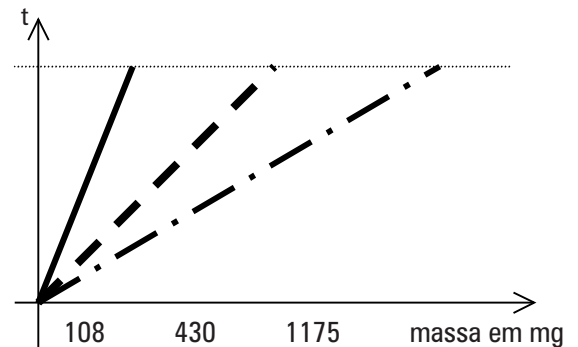

- · · solo natural - suelo natural - natural soil
- - - solo com bentonita - suelo con bentonita - soil with bentonite
- solo com Fastgel - suelo con Fastgel - soil with Fastgel

FASTGEL

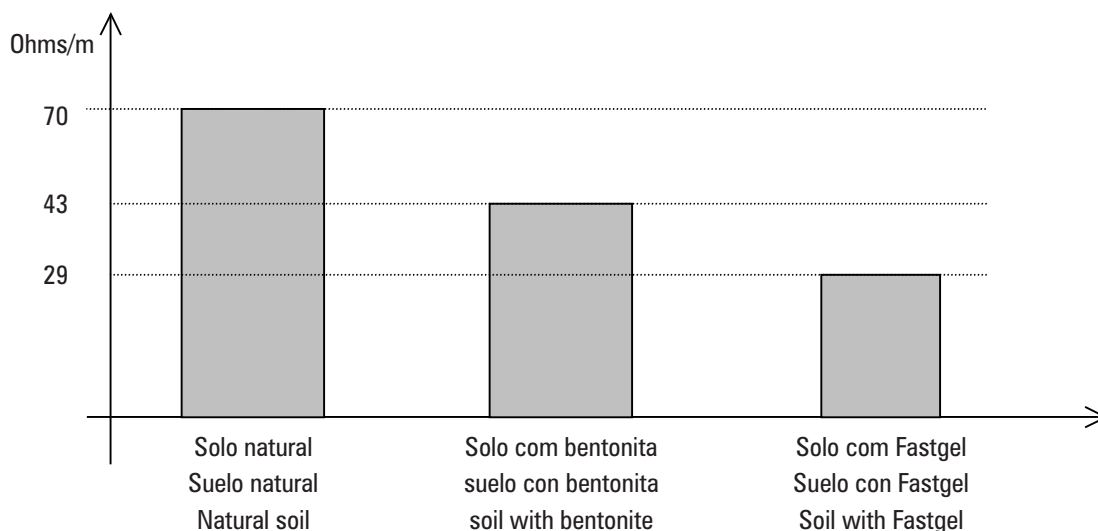

Estes valores podem variar em função do tipo solo
 Estos valores poden cambiar en funcion del tipo de suelo
 This values can be change in function of the soil type

APLICAÇÃO

APLICACIÓN

APPLICATION

COMO UTILIZAR O FASTGEL EM HASTES SIMPLES

COMO UTILIZAR EL FASTGEL EN VARILLA SIMPLES

HOW TO USE THE FASTGEL IN A SIMPLE GROUND ROD

PASSO 1 - 1st. step

Abrir um buraco em torno da haste (80x80 cm);
 Abrir uno hoyo alrededor de la varilla (80 x 80cm)
 Open a hole around the rod (80 x 80cm)

PASSO 2 - 2nd. step

Misture o FASTGEL com a metade da terra retirada, deixando a outra metade para tapar o buraco./ Mezcle todo el contenido de la bolsa de FASTGEL con la mitad de la tierra sacada del hoyo, deje la otra mitad para tapar lo./Mix half of the withdraw soil with the FASTGEL and leaves the other half to cover the hole.

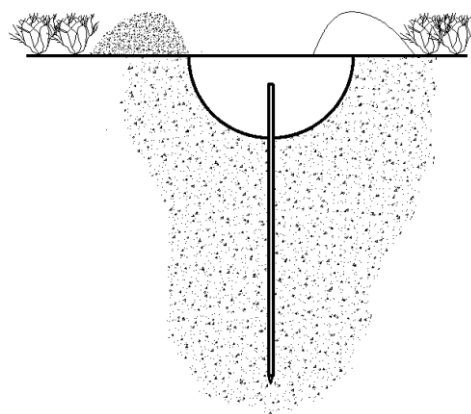
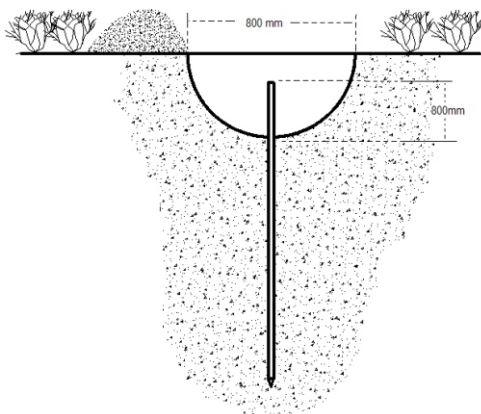

PASSO 3 - 3rd. Step

Despeje a mistura no buraco em volta da haste/ Ponga la mezcla alrededor de la varilla./Put the mixture around the rod.

PASSO 4 - 4th step

Adicione sobre a mistura, 20 litros de água e revolva o composto até formar uma pasta./ Vierta 20 litros de agua sobre la tierra mezclada con FASTGEL y revuelva hasta formar una pasta./Put inside the hole with FASTGEL, about 20l of water and mix to obtain a paste.

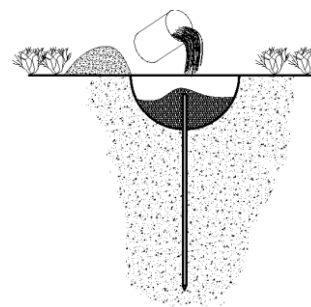
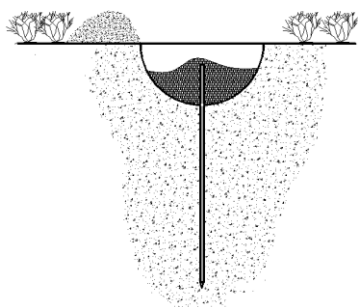

PASSO 5

Reponha sobre o tratamento a outra metade da terra compactando-a levemente e o tratameto está pronto.
Tape el hoyo con la otra mitad de la tierra. Put the other half of the withdrawn soil in the hole and it will be read.

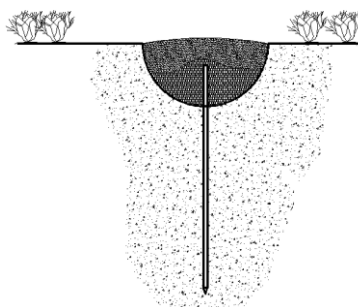

COMO CALCULAR A QUANTIDADE DE FASTGEL PURO EM TRATAMENTOS HORIZONTAIS OU VERTICAIS



$Q_f = S \times F$

Qf = FASTGEL (g)
 $S = (\pi r^2 h)$ $r = D/2$, $\pi = 3,1416$
 $F = 0,000925g/mm^3$
 EX:
 $D = 200mm$ $D/2 = 100mm$
 $h = 2400mm$

$Q_f = (3,1416 \times 100^2 \times 2.400) \times 0,000925 = 69743,5g = 69,7 Kg$

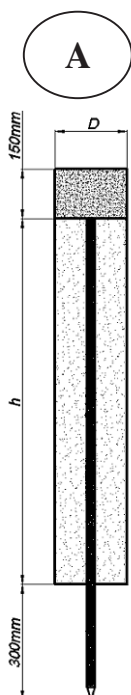

Adicionar Agua

COMO CALCULAR LA CANTIDAD DE FASTGEL PURO EN TRATAMIENTOS HORIZONTALES O VERTICALES

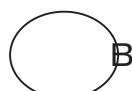

$Q_f = L \times h \times F \times E$
 $Q_f = \text{FASTGEL (g/m)}$

$F = 0,000925g/mm^3$
 $L = \text{largura/ancho/widht}$
 $H = \text{Profundidade/profundidad/depth}$
 $E = \text{comprimento/estencion/extencion}$
 EX:
 $L = 200mm$
 $h = 200mm$
 $E = 1000mm$

$Q_f = 200 \times 200 \times 0,000925 \times 1000$
 $Q_f = 37000 g = 37 kg/m$

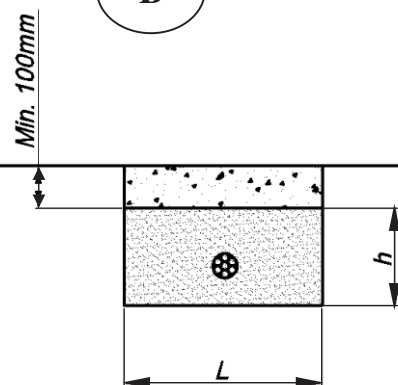

Add Water

Pode-se utilizar o FASTGEL puro ou misturado com a terra.
 Pode se utilizar el Fastgel puro o mezclado con tierra
 You can use pure Fastgel or mixed with soil

COPPER BONDED GROUND RODS

VARILLAS DE PUESTA A TIERRA

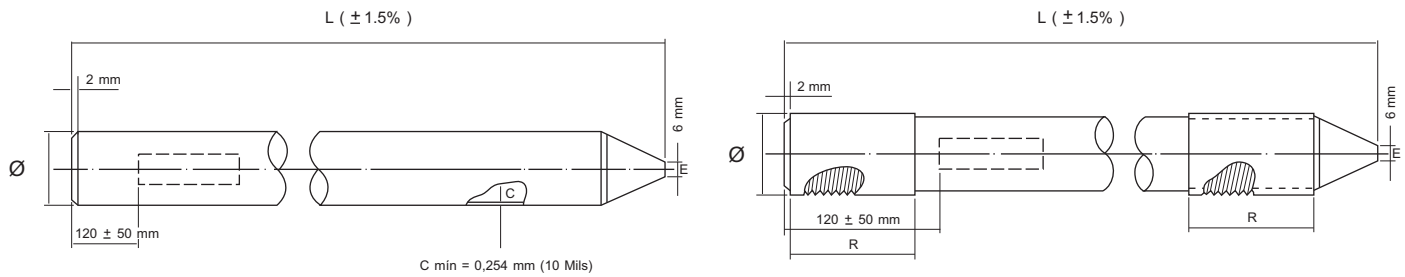

CÓDIGO FASTWELD FASTWELD CODE		DIMENSÕES - DIMENSIONS - DIMENSIONES						
NORMAL STANDARD NORMAL	PROLONGÁVEL SECTIONAL EXTENSIVO	Ø NOMINAL NOMINAL Ø	Ø REAL ACTUAL Ø	COMPRIENTO LENGTH EXTENSION		ROSCA THREAD ROSCA UNC	COMPRIENTO ROSCA LENGTH EXTENSION ROSCA mm (FWP)	PESO WEIGHT PESO KG
		POLEGADA INCHES	mm	PÉS FEET PIES	mm	(FWP)		
FW-512		1/2"	12,70	5	1.524			1,52
FW-612				6	1.829			1,82
FW-712				7	2.134			2,12
FW-812				8	2.438			2,42
FW-1012				10	3.048			3,03
FW-558	SFW-558	5/8"	14,30	5	1.524			1,92
FW-658	SFW-658			6	1.829			2,31
FW-758	SFW-758			7	2.134	5/8"	35	2,69
FW-858	SFW-858			8	2.438			3,07
FW-1058	SFW-1058			10	3.048			3,84
FW-534	SFW-534	3/4"	17,30	5	1.524			2,86
FW-634	SFW-634			6	1.829			3,44
FW-734	SFW-734			7	2.134	3/4"	35	4,01
FW-834	SFW-834			8	2.438			4,58
FW-1034	SFW-1034			10	3.048			5,73
FW-81	SFW-81	1"	23,00	8	2.438			8,52
FW-101	SFW-101			10	3.048	1"	50	10,65

* NBR 13571/96 - * UL-467 - * ANSI C-33-8

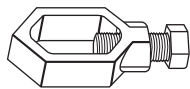

GRAMPO DE ATERRAMENTO - ABH ABH - GROUND ROD CLAMPS GRAPA DE VARILLAS - ABH		
Ø NOMINAL	CÓDIGO - CODE	Ø CABO - Ø CABLE
1/2"	ABH-12	10 - 50mm ²
5/8"	ABH-58	10 - 50mm ²
3/4"	ABH-34	10 - 50mm ²
1"	ABH-1	10 - 50mm ²



LUVAS DE EMENDA - COUPLINGS - MANGUITOS		
Ø	UNC	CÓDIGO - CODE - CÓDIGO
5/8"	5/8"	SC - 58
3/4"	3/4"	SC - 34
1"	1"	SC - 1

PARAFUSOS DE CRAVAR - DRIVINGS STUDS - TORNILLO		
Ø	UNC	CÓDIGO - CODE - CÓDIGO
5/8"	5/8 X 2"	DS - 58
3/4"	3/4 X 2"	DS - 34
1"	1 X 2"	DS - 1

TRENZA PARA ATERRAMIENTO

GROUND BRAIDS

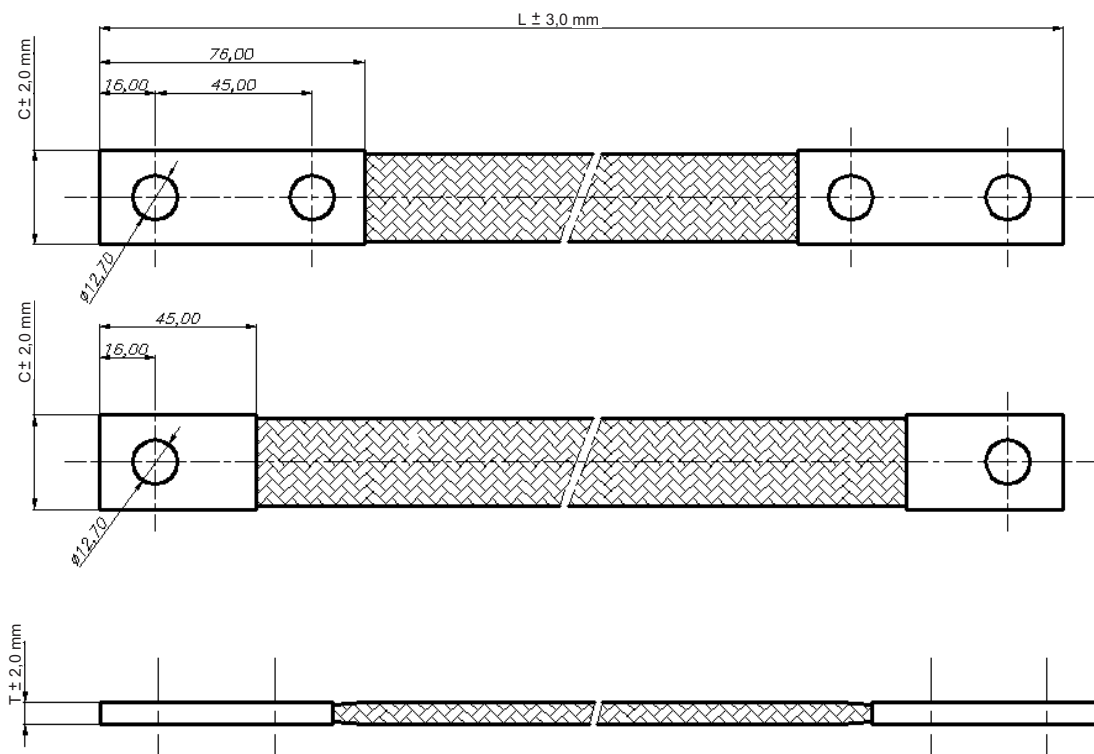

REFERÊNCIA PART NUMBER	A Maxima/maximum (amper)*	Quant. Cordoalhas Cantidad de trenzas Braids quantity	SEÇÃO SECCION mm ²	C (mm)	T (mm)	L (mm)
CF-190-30 CF-190-60	190	1	25	24	3	300 600
CF-330-30 CF-330-60	330	2	50	24	5	300 600
CF-470-30 CF-470-60	470	3	75	26	7	300 600
CF-600-30 CF-600-60	600	4	100	30	10	300 600

$t_a = 35\text{ }^{\circ}\text{C}$ - $t_{max} = 105\text{ }^{\circ}\text{C}$

Para terminais com dois furos acrescente à referencia, o sufixo 2F

Para terminales con dos huecos añadir a la referencia el sufijo 2F

For lug with two holes insert to the part number the suffix 2F

Ex.: CF-190-60 2F



Bogotá Sala de Ventas

Carrera 12 No 13 - 46
PBX: 6013360755 - 6013412439
Celular: 312 3055335

Centro de Distribución

Carrera 18 No 19A - 36
PBX: 6013360755 EXT: 2101

SEÇÃO
SECCIÓN
SECTION

10

INFORMAÇÕES TÉCNICAS

INFORMACIONES TECNICAS

TECHNICAL INFORMATION

<p>CARACTERÍSTICAS ELÉTRICAS MECÂNICAS E TERMICAS DO COBRE E ALUMÍNIO</p> <p>CARACTERISTICAS ELECTRICAS MECANICAS Y TERMICAS DEL COBRE Y ALUMINIO</p> <p>ELECTRIC, MECHANICAL AND THERMIC COPPER AND ALUMINIUM CHARACTERISTICS</p> <p>PÁG. 10 - 1</p>	<p>FATORES DE CONVERSÃO</p> <p>FACTORES DE CONVERSION</p> <p>CONVERSION FACTORS</p> <p>PÁG. 10 - 2</p>
<p>CONVERSÃO DE TEMPERATURA</p> <p>CONVERSION DE TEMPERATURA</p> <p>TEMPERATURE CONVERSION</p> <p>PÁG. 10 - 3</p>	<p>TABELA GENÉRICA DE CALCULO ELÉTRICO</p> <p>TABLA DE CALCULO ELECTRICO</p> <p>ELECTRICAL DATA CALCULATION</p> <p>PÁG. 10 - 4</p>
<p>FIOS E CABOS DE COBRE</p> <p>COPPER WIRE AND CABLES</p> <p>HILOS Y CABLES DE COBRE</p> <p>PÁG. 10 - 5</p>	<p>BARRAMENTO DE COBRE</p> <p>BARRA DE COBRE</p> <p>COPPER BUS BAR</p> <p>PÁG. 10 - 6</p>



Bogotá Sala de Ventas

Carrera 12 No 13 - 46
PBX: 6013360755 - 6013412439
Celular: 312 3055335

Centro de Distribución

Carrera 18 No 19A - 36
PBX: 6013360755 EXT: 2101

CARACTERÍSTICAS ELÉTRICAS MECÂNICAS E TERMICAS DO COBRE E ALUMÍNIO

CARACTERISTICAS ELECTRICAS MECANICAS Y TERMICAS DEL COBRE Y ALUMINIO

ELECTRIC, MECHANICAL AND THERMIC COPPER AND ALUMINIUM CHARACTERISTICS

		Cobre Copper	Aluminio Aluminium
CONDUTIVIDADE } 20° C CUNDUCTIVIDAD } CONDUTIVITY	$\frac{m}{\text{Ohm.mm}^2}$ duro(hard) recozido(annealed)	56 58	35 36
MASSA ESPECÍFICA } 20° C	$\frac{g}{\text{cm}^3}$	8,89	2,7
COEFICIENTE DE DILATAÇÃO LINEAR / °C COEFICIENTE DE DILATACION LINEAR / °C		0,000017	0,000024
COEFICIENTE DE VARIAÇÃO DE RESISTENCIA COM TEMPERATURA COEFICIENTE DE VARIACION DE LA TEMPERATURA	°C °C ⁻¹	0,00393	0,004
COEFICIENTE DE TRANSMISSÃO DE CALOR COEFICIENTE DE TRANSMISSION DEL CALOR	$\frac{\text{cal}}{\text{cm} \cdot \text{°C} \cdot \text{s}}$	0,9	0,5
COEFICIENTE DE TRANSMISSÃO DE CALOR	$\frac{W}{\text{cm} \cdot \text{°C}}$	3,76	2,09
CARGA DE RUPTURA	$\frac{\text{Kgf}}{\text{mm}^2}$ duro (hard) recozido (annealed)	38 - 45 25 - 30	15 - 19 10 - 12
ALONGAMENTO	% duro (hard) recozido (annealed)	0,8 - 1,5 23 - 33	1,2 - 2 3 - 8
PONTO DE FUSÃO PUNTO DE FUSION	°C	1.083	658

FACTORES DE CONVERSION

CONVERSION FACTORS

<i>MULTIPLICAR MULTIPLY</i> →	<i>POR BY</i>	<i>PARA OBTEN / OBTENER TO OBTAIN</i>
POLEGADA PULGADA INCHES	0,0254	METRO METER
POLEGADA PULGADA INCHES	25,4	MILIMETROS MILIMETER
MILS	0,001	POLEGADA PULGADA INCHES
MILS	0,0254	POLEGADA PULGADA INCHES
PÉS PIES FEET	0,3048	METRO METER
JARDAS YARDAS YARDS	0,9144	METRO METER
MILHAS MILLAS STATUTE MILE	1,6093	QUILOMETROS KILOMETRO KILOMETER
MILIMETRO QUADRADO MILIMETRO CUADRADO SQUARE MILIMETER	1973	MCM (MIL CIRCULAR MILS)
MILIMETRO MILIMETERS	39,7	MILS
MILIMETRO MILIMETERS	0,03937	POLEGADAS PULGADAS INCHES
CENTIMETRO CENTIMETER	0,3937	POLEGADAS PULGADAS INCHES
CENTIMETRO CENTIMETER	0,032808	PÉS PIES FEET
CIRCULAR MILS	0,0005067	MILIMETROS CUADRADOS MILIMETROS CUADRADOS SQUARE MILIMETER
MILS ²	1,2732	CIRCULAR MILS
POUNDS	0,45359	KILOGRAMAS
POLEGADAS QUADRADAS PULGADAS CUADRADAS SQUARE INCHES	6,452	CENTIMETROS QUADRADOS CENTIMETROS CUADRADOS SQUARE CENTIMETER
PÉS QUADRADOS PIES CUADRADOS SQUARE FEET	0,0929	METROS QUADRADOS METROS CUADRADOS SQUARE METER
JARDAS QUADRADAS YARDAS CUADRADAS SQUARE YARDS	0,8361	METROS QUADRADOS METROS CUADRADOS SQUARE METER
MILHAS QUADRADAS MILLAS CUADRADAS SQUARE MILES	2,590	QUILOMETROS QUADRADOS KILOMETROS CUADRADOS SQUARE KILOMETER
POLEGADAS CUBICAS PULGADAS CUBICAS CUBIC INCHES	16,387	CENTIMETROS CUBICOS CUBIC CENTIMETER
PES CUBICOS PIÉS CUBICOS CUBIC FEET	1728	POLEGADAS CUBICAS PULGADAS CUBICAS CUBIC INCHES
Ohms/Km	0,3048	Ohms/1000 pés Ohms/1000 piés Ohms/1000 feet
Ohms/Km	1,6093	Ohms/1000 milha Ohms/1000 milla Ohms/1000 mile
<i>PARA OBTEN/OBTENER TO OBTAIN</i>	<i>POR BY</i> ←	<i>DIVIDIR TO DIVIDE</i>

FATORES PARA CÁLCULO

FACTORES PARA CALCULO

FACTORS FOR CALCULATION

TEMPERATURA	CALCULO	=
° FAHRENHEIT	$^{\circ}\text{C} = (^{\circ}\text{F} - 32)/1,8$	° CENTIGRADO (CELSIUS)
° CENTIGRADO (CELSIUS)	$^{\circ}\text{F} = ^{\circ}\text{C} \times 1,8 + 32$	° FAHRENHEIT
° CENTIGRADO (CELSIUS)	$\text{K} = ^{\circ}\text{C} + 273,15$	KELVIN
KELVIN	$^{\circ}\text{C} = \text{K} - 273,15$	CELSIUS

FATORES E CONSTANTES PARA MATERIAIS

FACTORES Y CONSTANTES PARA LOS MATERIALES

CONSTANT AND FACTORS FOR MATERIAL

TIPO CONDUTOR	TIPO DEL CONDUCTOR	CONDUCTOR TYPE	Conductividade Conductivity (%)	Fator Factor α_r 20° C	$K_0(1/\alpha_0)$ 0° C	Temp. de fusão (fusion) (°C)	Resistividade Resistividad (Resistivity) ρ_r (20 °C) ($\mu\Omega\text{-cm}$)	TCAP (J/cm ³ /°C)
cobre (recozido)	Cobre recocado	Copper annealed	100.0	0,00393	234	1083	1,724	3,422
cobre (duro)	Cobre duro	Copper hard	97.0	0,00381	242	1084	1,777	3,422
aço-cobreado 40%	Acero-cobreado	Steel copper	40.0	0,00378	245	1084	4,397	3,846
aço-cobreado 30%	Acero cobreado	Steel copper	30.0	0,00378	245	1084	5,862	3,846
fio de alumínio	Hilo aluminio	Aluminum wire	61.0	0,00403	228	657	2,862	2,556
liga de alumínio 5005	Aleacion aluminio 5005	Aluminum alloy 5005	53.5	0,00353	263	652	3,223	2,598
liga de alumínio 6201	Aleacion aluminio 6201	Aluminum alloy 6201	52.5	0,00347	268	654	3,284	2,598
aço-alumínio	Acero aluminio	Steel aluminum	20.3	0,00360	258	657	8,481	2,670
haste aço cobreado (1)	Varilla acero y cobre	Steel copper rod	20.0	0,00378	245	1084	8,621	3,846
aço zincado	Acero cincado	Galvanized steel	8.6	0,00320	293	419	20,1	3,931
aço inoxidável 304	Acero inoxidable	Inox steel	2.4	0,00130	749	1400	72,0	4,032

(1) Considerando espessura mínima do revestimento de cobre de 0,254mm conforme norma NBR 13.571. - Considerando un espesor de 254 micrones de cobre. - Considering 0,254mm copper tickness.

CONEXÃO - CONEXION - CONNECTION		Tm °C	Kf
A (1)	Mecânica (aparafusada ou por pressão/compressão)	250	11,5
	Macanica (tornillada o por presion/compresion)		
	Mechanical (screw or press/compres)		
B	Solda oxiacetilénica convencional	450	9,2
	Oxiacetilénic weld		
C	Solda exotermica	1083	7,1
	Soldadura exotermica		
	Exothermic weld		

(1) - exceto os que atendam aos requisitos mecânicos e elétricos da norma IEEE-837 excepto para que cumpla los requisitos mecanicos y electricos de la norma IEEE-837..Except those wich have been tested to and passed in the requirements of IEEE 837-2000

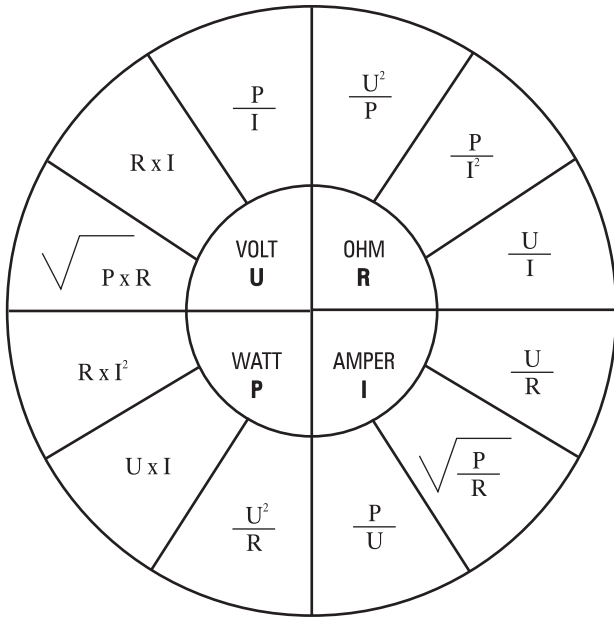

U = TENSÃO / TENSION = VOLTS
 I = CORRENTE / CORRIENTE / CURRENT = AMPER
 P = POTENCIA / POWER = WATTS
 R = RESISTÊNCIA / RESISTENCE = OHMS

CALCULO DE CONDUTORES PARA ATERRAMENTO
CALCULO DE CONDUTORES PARA PUESTA TIERRA
GROUNDING CONDUCTOR CALCULATION

<p>ONDERDONK</p> $S = I_f \sqrt{\frac{t \cdot \alpha_r \cdot \rho_t \cdot 10^4}{TCAP \cdot \ln \frac{(k_o + T_m)}{(k_o + T_a)}}}$	<p>SIMPLIFICADA - SIMPLIFIED</p> $S = I_t \cdot k_f \cdot \sqrt{t}$
--	--

<p>S = seção mínima - seccion minima - minimum section I_f = corrente de falta fase-terra corriente de falta fase-tierra fault phase ground current t = tempo - tiempo - time α_r = coeficiente térmico de resistividade do condutor a t °C (°C⁻¹) coeficiente termico de resistividad del conductor a t °C (°C⁻¹) termic coeficiente of resistivity conductor in t °C (°C⁻¹) ρ_t = resistividade do condutor de terra a t °C (Ohm.cm) TCAP = fator de capacidade térmica (J/cm³/°C) Factor de la capacidad termica (J/cm³/°C) T_m = temperatura máxima suportável (pagina 10-3) temperatura maxima soportable (pagina 10-3) maximum suportable temperature (page 10-3)</p>	<p>T_a = temperatura ambiente Ambient temperature k_o = 1/α_o, ou (1/α_r) - Tr k_o = coeficiente térmico de resistividade do condutor a 0° C coeficiente termico de la resistividad del conductor a 0° C resistivity termic coeficient from conductor in 0° C Tr = temperatura de referência da constante do material (°C) temperatura de referencia de la constante del material (°C) materials constant reference temperature (°C) K_f = constante para materiais considerando temperatura ambiente (T_a) de 40°C Constante para los materiales considerando temperatura ambiente (T_a) de 40°C Materials constant considering 40°C from ambient temperature (T_a)</p>
---	---

COPPER WIRE AND CABLES

HILOS Y CABLES DE COBRE

FIOS DE COBRE - COPPER WIRE - HILOS DE COBRE			
Seção Nominal Seccion Nominal Nominal Section (mm ²)	Diâmetro Nominal Diametro Nominal Nominal Diameter (mm)	Resistência Resistencia Resistance (Ohms/Km 20° C)	Peso Weight (Kg/Km)
4	2,24	4,62	35,00
6	2,80	2,95	54,70
10	3,55	1,84	88,00
16	4,50	1,14	141,40

CABOS DE COBRE - COPPER CABLE - CABLES DE COBRE					
Seção Nominal Seccion Nominal Nominal Section (mm ²)	Formação - Composition		Diâmetro Nominal Diametro Nominal Nominal Diameter (mm)	Resistência Resistencia Resistance (Ohms/Km 20° C)	Peso Weight (Kg/Km)
	Nº Fios Nr. Wires Nº Hilos	Diâm. Fio Diam. Wire Diam. Hilo			
10	7	1,36	4,08	1,820	92,20
16	7	1,70	5,10	1,170	144,10
25	7	2,06	6,18	0,795	211,60
35	7	2,50	7,50	0,538	311,60
50	7	3,00	9,00	0,375	448,70
70	7	3,45	10,35	0,283	593,40
70	19	2,12	10,80	0,276	739,39
95	7	4,12	12,36	0,199	846,20
95	19	2,50	12,50	0,198	855,78
120	19	2,90	14,50	0,148	1054,00
150	19	3,25	16,25	0,118	1299,00
185	19	3,55	17,75	0,099	1621,00
240	19	4,00	20,00	0,077	2141,00

CABOS DE COBRE COMPACTADO - COPPER CABLES COMPACTED - CABLES DE COBRE COMPACTADO			
Seção Nominal Nominal Section (mm ²)	Diâmetro Nominal Nominal Diameter (mm)	Resistência Resistance (Ohms/Km 20° C)	Peso Weight (Kg/Km)
10	3,80 C	1,830	89,00
16	4,80 C	1,150	141,00
25	6,00 C	0,727	221,00
35	6,75 C	0,524	303,00
50	8,10 C	0,387	415,00
70	9,55 C	0,268	593,00
95	11,30 C	0,193	825,00
120	13,20 C	0,153	1040,00
150	14,80 C	0,124	1295,00
185	16,40 C	0,0991	1607,00
240	18,00 C	0,0754	2111,00

CONDUCTORES DE ACERO Y COBRE

STEEL COPPER CONDUCTORS

FIOS DE AÇO-COBRE - COPPER STEEL WIRE - HILOS DE ACERO-COBRE

AWG	Seção Nominal (mm ²)	Diâmetro Nominal	Resistência - Resistance		Peso
	Nominal Section (mm ²)	Nominal Diameter	(Ohms/Km 20° C)		Weight
	Seccion Nominal	(mm)	30%	40%	(Kg/Km)
4	21,15	5,19	2,772	2,079	172,30
5	16,76	4,62	3,497	2,623	136,30
6	13,3	4,12	4,408	3,306	108,40
9	6,63	2,91	8,838	6,629	54,10

CABOS DE AÇO-COBRE - COPPER STEEL CABLE - CABLES DE ACERO-COBRE

Formação	Seção Nominal (mm ²)	Diâmetro Nominal	Resistência - Resistance		Peso
	Nominal Section (sq.mm)	Nominal Diameter	(Ohms/Km 20° C)		Weight
	Formación Seccion Nominal (mm ²)	(mm)	30%	40%	(Kg/Km)
3 X 7AWG	31,65	7,9	1,8670	1,4006	260,00
3 X 8AWG	25,10	7,04	2,3540	1,7661	206,10
3 X 9AWG	19,90	6,27	2,9690	2,2270	163,50
3 X 10AWG	15,78	5,59	3,7430	2,8081	129,70
7 X 10AWG	36,83	7,77	1,6080	1,2060	303,10
7 X 8AWG	58,56	9,78	1,0110	0,7585	482,00
7 X 7AWG	73,87	11,00	0,8018	0,6014	607,80
7 X 6AWG	93,10	12,30	0,6358	0,4770	766,40
7 X 5AWG	117,40	13,90	0,5043	0,3783	966,40

BARRA DE COBRE RETANGULAR

RECTANGULAR COPPER BUS BAR

ESPESSURA	LARGURA	PESO/WEIGHT			
		ESPESSOR	ANCHO	ibs per foot	kg por km
1/8"	1"	0,484	0,72		
	1-1/2"	0,726	1,07		
	2"	0,969	1,43		
3/16"	1"	0,727	1,08		
	2"	1,45	2,15		
1/4"	1"	0,969	1,43		
	1-1/2"	1,45	2,15		
	2"	1,94	2,87		
	3"	2,91	4,31		
3/8"	4"	3,88	5,74		
	1"	1,45	2,15		
	1-1/2"	2,18	3,23		
	2"	2,91	4,30		
1/2"	3"	4,36	6,46		
	4"	5,81	8,61		
	2"	3,88	5,74		
	3"	5,81	8,61		
	4"	7,75	11,48		